



EL.MOTION

BLDC motors

Continuous acquisition and control
of position, speed and torque

Contents

We drive innovation	4
Rotary drive units AD 11/12/14	5
Linear drive units AG 72/91/93/96	5
Drive technology	6
Customer benefits	7
ASI (Automatic System Identification)	8
Functional safety	9
Control structure of the EL.MOTION drives	10
Web-based management	11
Rotary drive units AD 11 AD 11 STO	12
Rotary drive units AD 12 AD 12 STO	14
Rotary drive unit AD 14	16
Dimension drawing 158972 for AD 11_3 AD 12_3 AD 14_3	18
Dimension drawing 158974 for AD 11_2 AD 12_2 (STO)	19
Connection diagram AD 1103 AD 1203 AD 1403	20
Connection diagram AD 1102 AD 1202 (STO)	20
Industry 4.0 – Production meets digitization	21
Planetary gearboxes	22
Dimension drawing for AD drive with planetary gearbox	23
Angular gearboxes	24
Dimension drawing for AD drive with angular gearbox	25
Solid and hollow shaft gearboxes	26
Dimension drawing for AD drive with solid and hollow shaft gearbox	27
Modular safety braking system ROBA-topstop	28
Expansion unit for easy machine integration	29
Linear drive unit AG 72	30
Dimension drawing for AG 72	31
Linear drive units AG 91/93	32
Dimension drawing for AG 91/93	33
Linear drive unit AG 91/93 STO	34
Dimension drawing for AG 91/93 STO	35
Linear drive units AG 96	36
Dimension drawing for AG 96	37
Formulas used for drive calculations	38
Questionnaire	39

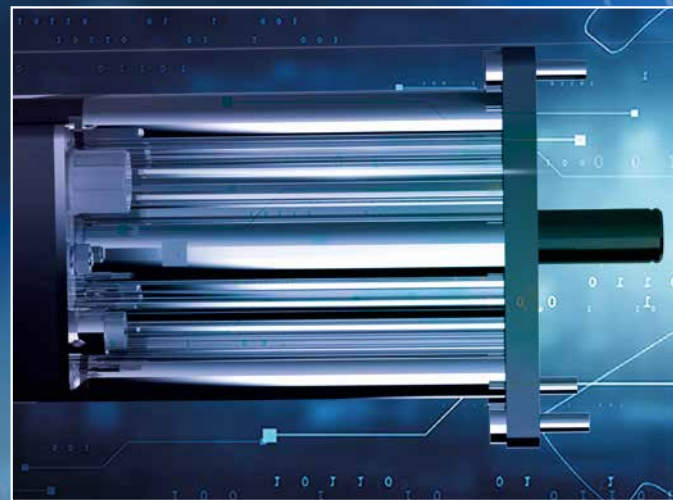

FOCUS ON CUSTOMER SATISFACTION

INTELLIGENT TECHNOLOGY · SMART PRODUCTS

INTERNATIONAL LOCATIONS · WORLDWIDE AVAILABILITY



CUTTING-EDGE TECHNOLOGY AT HOME ALL OVER THE WORLD



Erhardt+Leimer **Global solutions for production of the future**

Intelligent technologies and products in the highest quality designed to optimize the production processes of our customers all around the world. This is our claim as the internationally expanding Erhardt+Leimer group of companies.

With our global presence – from development to production and on to service – we are always close to the customer. We develop customer-specific solutions and provide our customers with excellent products either in digital or intelligent versions depending on their preference. Not only this, but we also set new standards for the production of tomorrow. In the process, it is not just our products that are increasingly becoming smart – our entire company is currently undergoing a digital transformation. One visible indication of this is the E+L online shop, which enables our customers to order products and spare parts quickly and easily from our website.

With more than 1,600 employees at sites across Europe, Asia, and America we deliver cutting-edge technology on-time to any location in the world.

In everything we do, we aim to use all company resources responsibly to protect the environment and demonstrate our commitment to increased sustainability.



We drive innovation

Individual by default

Clear technical challenges are currently emerging in the machinery and mechanical engineering sector: the need for modernization, simplification, and standardization. At the same time, there is also a demand for extreme flexibility and agile processes, i.e. fast implementation combined with great ability to adapt to ever changing requirements. These opposing demands are often faced by engineering departments that tend to be overworked, frequently resulting in conflicting goals during implementation. The drive technology is an essential driving force in all production setups, so when it comes to reconciling the technical conditions with the day-to-day reality of the production environment, it plays a central role. This means that it is also high time to find answers and solutions to allow drive units to be adapted quickly, easily, and reliably.

Erhardt+Leimer is facing up to this challenge with its state-of-the-art drive concept EL.MOTION, which sets new standards for Industry 4.0.

Brushless drive technology

Our brushless drive technology is a tried-and-tested and highly successful product that has been developed by Erhardt+Leimer based on the company's own know-how and many years of practical experience. It is now used in a wide range of systems at our customers. Through careful selection of components, highest quality standards, and international certifications we can ensure that this series of drives is perfect for automation solutions requiring fast reactions, precise control, and the utmost reliability. All servo motors are by design highly dynamic and incredibly stable, making them ideal for many different potential applications. They are particularly suited e.g. to positioning tasks in industrial robotics, in machine tools, actuators, and machine automation.

Direct drive solutions

Erhardt+Leimer offers linear and rotary direct drive solutions that are suitable for a wide range of different tasks thanks to their backlash-free design, and they stand out with exceptional stall torque and high acceleration capability. By removing all mechanical power transmission components, we enable our customers to make considerable time and cost savings during machine servicing and ensure easy integration in the machine layout. The drives consist of a housing made of extruded aluminum and a rotor with an iron core that offers a high power density.

Thanks to the resulting complete elimination of the type of backlash associated with conventional drive systems and the mechanical elasticity of the drive, the EL.MOTION motors are perfect for applications that demand extremely quiet and smooth running coupled with very precise positioning accuracy.

Application areas				
 Ceramics & Glass	 Food Industry	 Freight Transport Industry	 Paper Industry	 Printing Industry
 Rubber Industry	 Textile Industry	 Wood Industry	 Mechanical & Electronic Industry	 Flexo Printing Press
 Packaging Industry	 Automatic Industrial Gates	 Converting Industry	 Hygiene Industry	 Medical Sector
 Plastics Industry	 Web Positioning	 Process Engineering	 Industrial Automation	 Battery Industry
 Replacement for Pneumatic Applications	 Mobile Platforms & Elevators	 Corrugated Board Industry	 Metal Industry	 Intralogistics

Rotary drive units AD 11/12/14

The rotary drive units AD 11, AD 12, and AD 14 are synchronous machines with a high power density. With very compact component dimensions, these motors achieve a torque output in the range from 1 to 4 Nm at speeds between 230 and 1000 rpm, offering a gearbox-free solution for many applications. High axial loads can also be handled without problems thanks to the additional support provided by a two-row slanting ball bearing. As a result, the drive units can be connected directly – without a coupling – to a machine, which makes them very easy to integrate in existing production lines.



Rotary drive unit AD 11



Rotary drive unit AD 12



Rotary drive unit AD 14

Linear drive units AG 72/91/93/96

The linear drive units AG 72, AG 91, AG 93, and AG 96 are synchronous motors with high positional accuracy and control dynamics. The nominal actuating forces of the relevant motors are in the range from 250 to 5500 N at a speed rate of up to 60 mm/s. The linear drive units are particularly well suited to long-term applications and are used e.g. on moving webs for web control at unwinding and rewinding stations.



Linear drive unit AG 72



Linear drive unit AG 91



Linear drive unit AG 93

Drive technology

Drive structure

- Cascaded control
- Direct drive solution
- Reduced cabling
- Brushless technology

Networking / communication

- Profinet (GSD)
- EtherNet/IP (EDS)
- EtherNet UDP/IP
- POWERLINK

Integration

- Machine network
- Easy diagnostic options
- Internal process monitoring

Setup

- Web-based management
- Automatic System Identification (ASI)
- Visualization of the commissioning process



What our technology offers

■ High power density

The rotor pack in our drives features a very high share of iron. As a result, our drives are extremely powerful and offer very stable positioning. They are designed especially for use in dynamic, high-precision positioning applications.

■ High axial load bearing capacity

Thanks to the use of a two-row slanting ball bearing on the drive side of the drive, the rotor shaft is capable of withstanding increased axial loads. As a result, it is not always necessary to use a coupling to reduce axial loads.

■ Integrated electronics

Our drives feature integrated power and communication electronics. This offers our customer space and cost savings with regard to integration in their machine concept.

■ Operating range up to 50 °C

Our drives are designed to be used all around the world. Noticeable power degradation does not occur until ambient temperatures reach 50 °C or higher.

■ High network compatibility

To ensure that they are ready to be deployed in a wide range of industries, a large number of industry-standard fieldbus interface protocols are already integrated in our drives.

■ Multiturn

Our drives feature a multiturn encoder for position feedback. This in-house development allows us to permanently store the absolute position value without needing to access a storage medium.

■ Low voltage 24 V

Our drive technology has been specially developed for use in low-voltage 24 V DC applications.

■ Servo controller

Thanks to their cascaded control structure and closed-loop control functions, our drives provide production system developers with all the functions that would be covered by a commercially available external drive controller.

■ Fieldbus integration

Our fieldbus interfaces are certified in accordance with the manufacturers' guidelines and offer full integration in the machine network as well as standards-compliant transmission of data between the individual network nodes.

■ Parameterizable

The drives can be parameterized via web-based management. As a result, the process of commissioning and starting to use the drives is simple and intuitive.

50%

standard components allow flexible use of a wide range of different drive variants

25%

cost savings thanks to the use of decentralized drive concepts

40%

longer service life through intelligent process monitoring

Customer benefits

Control

The EL.MOTION product family consists of a range of intelligent drives in which the motor controller is already integrated in the drive. The motors are BLDC (brushless direct current) motors that are operated via the electronic controller as synchronous machines using a vector module. The drives can be used for position control, speed control, or torque control. In addition, the drives

offer the option of connecting two external limit switches directly to the drive. The combination of this distributed intelligence with a dedicated interface concept allows a decentralized drive topology to be implemented that greatly reduces wiring and space requirements in the control cabinet.

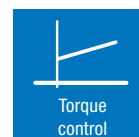
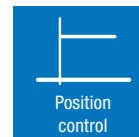

Communication

Erhardt+Leimer makes a wide range of communication standards available for its drives. The AD and AG series come with EL.NET technology, which allows both open and closed-loop control tasks to be implemented without any need whatsoever for an external controller. E+L has a large number of sensors and input/output modules available for this. All the drives come with web-based management on board as standard. This means that when the motor is connected via

Ethernet, it can be addressed from the browser of a PC, allowing you to check and adjust settings or query the current status. But that is not all: E+L also places great value on open connectivity and therefore also offers open access via EtherNet UDP/IP or via certified standard protocols such as EtherNet/IP, Profinet, and POWER-LINK. One IP address per drive needs to be reserved in the network for integration of the drives.

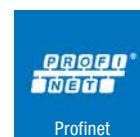

Safety

Both the communication protocols and the optionally available functional safety in accordance with EN 61508 (Safe Torque Off – STO) are all certified by TÜV, Germany's Technical Inspection Association. As standard, the drives are supplied with the protection class IP 54 and can be used up to an ambient temperature of 50°C.

The integrated "intelligence" means that the EL.MOTION drives are fully IoT-compatible. They enable predictive maintenance by providing access to performance data and temperature values. The web-based management offers integrated service and analysis tools, such as oscilloscopes and recording functions.



Efficiency

The high-resolution multiturm encoder (4096 pulses per revolution) guarantees high control accuracy and ensures the best efficiency in all operating ranges.

Thanks to the high power density, the compact design with simple cabling, and the guided commissioning process with Automatic System Identification (ASI), the drive series AD and AG are highly effective drive solutions.



ASI (Automatic System Identification)

Optimize your drives in a matter of seconds

Automatic System Identification (ASI) is a tool for quick and easy commissioning and for optimization of drive applications. In just a few seconds you can automatically and optimally adjust the parameters for the individual drive controllers of both the rotary and linear EL.MOTION drive units. Determination of the controller parameters is part of the guided commissioning process. Here, the parameters for compensation of the mass inertia of the load being moved and for compensation of friction effects are optimally adapted to the relevant customer application.

This means that high costs for servicing and commissioning of the drives are now a thing of the past – as is the need for specialist expertise in control technology on the side of the customer.

- "One-click" start Automatic System Identification (ASI)
- Customer-friendly guided commissioning and servicing via the integrated web-based management (WBM)
- Shortened commissioning times and reduced costs for our customers
- Optimized coordination of closed-loop control in the drive
- Resonance detection ensure that the control settings are kept at a safe margin to the stability limits
- Can be reapplied to changed moments of inertia at any time
- Higher clock rates for processes
- High stability and quality in motion control
- Optimized productivity for the customer's line



Determination of parameters
through test signals

"One-click"
start

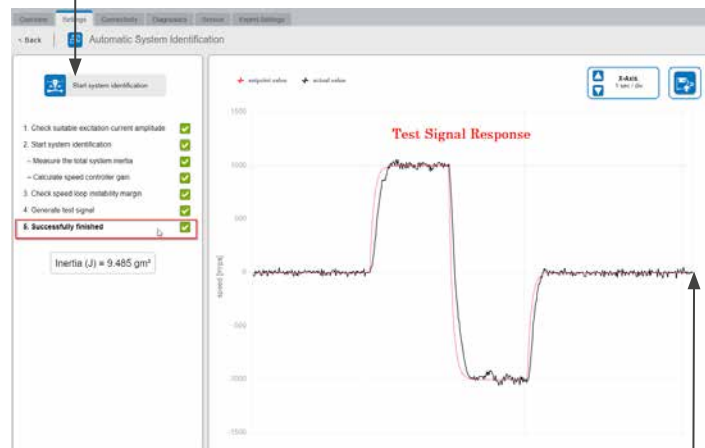

Result:
Optimized control results

Functional safety

"Safe Torque Off" (STO) function

- The safety function STO (Safe Torque Off) in accordance with EN 61800-5-2 is a safety function that is integrated in the drive; the safety function shuts down the motor torque by interrupting the control pulses. The safety function STO can be used wherever the actuating drive comes to a standstill by itself in a sufficiently short time due to the load torque or due to friction, or where "coasting down" of the actuating drive does not have any safety-related consequences. The stoppage position is not monitored.
- The safety function STO corresponds to Stop Category 0 in accordance with EN IEC 60204-1. The figures show the sequence over time for the two basic application examples for use of the STO function. (In the figures, Δt identifies the response time of the safety function.)

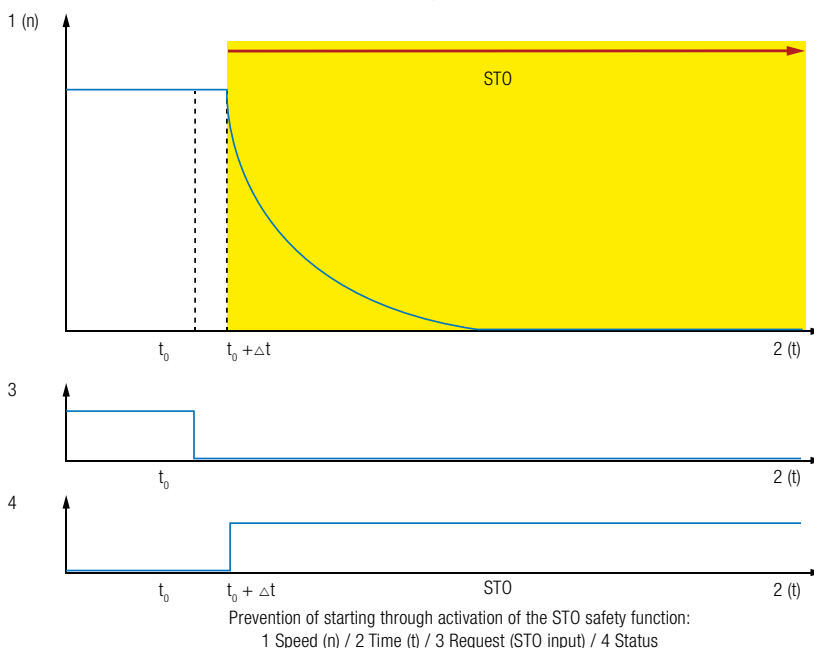

STO activation at standstill

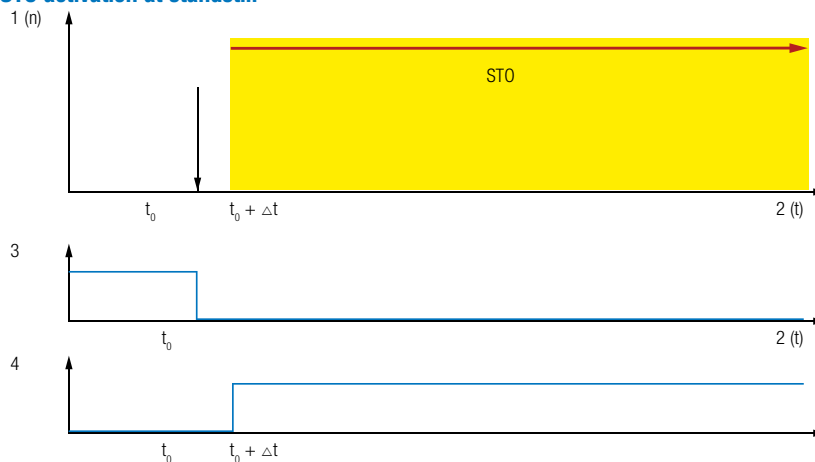

Prevention of starting through activation of the STO safety function:
1 Speed (n) / 2 Time (t) / 3 Request (STO input) / 4 Status

Block diagram (STO)

- The diagram opposite shows the internal layout of the actuating drive as a simplified block diagram. The integrated safety function is marked in yellow. The STO module has a two-channel architecture (channel A and channel B) and therefore achieves Performance Level d, Category 3 as per EN ISO 13849-1.
- The two shutdown channels are supplied by the STO-A and STO-B inputs and act on the safe pulse inhibit. If the safety function STO is activated, the control pulses to the power stage, and therefore the power supply to the motor, are interrupted by the two-channel safe pulse inhibit.

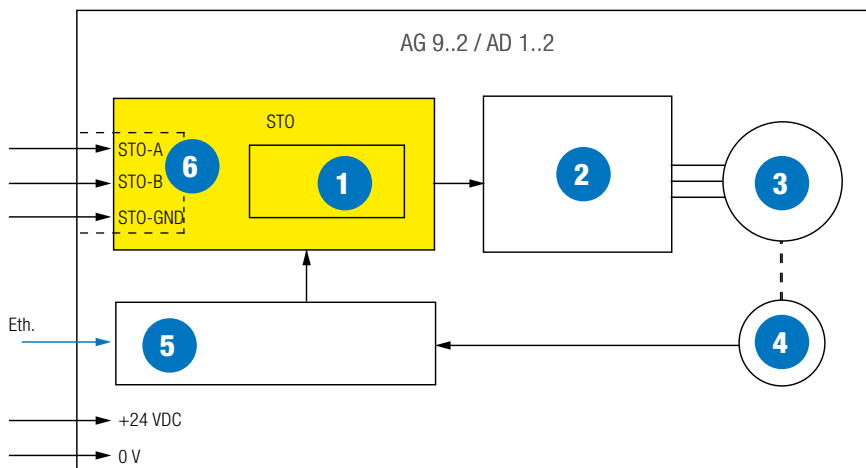

Simplified block diagram of the BLDC drive:
1 Impulse block / 2 Power stage / 3 Motor / 4 Multitrurn encoder / 5 Drive control / 6 Electrical isolation

Control structure of the EL.MOTION drives

The EL.MOTION drives use a classic cascaded controller module comprising torque, speed, and position controllers. To ensure the highest possible efficiency, a vector control model with sinusoidal commutation is used. With the aid of an integrated multiturn encoder, the absolute rotor position can be transmitted via the communication data block to the customer's control system.

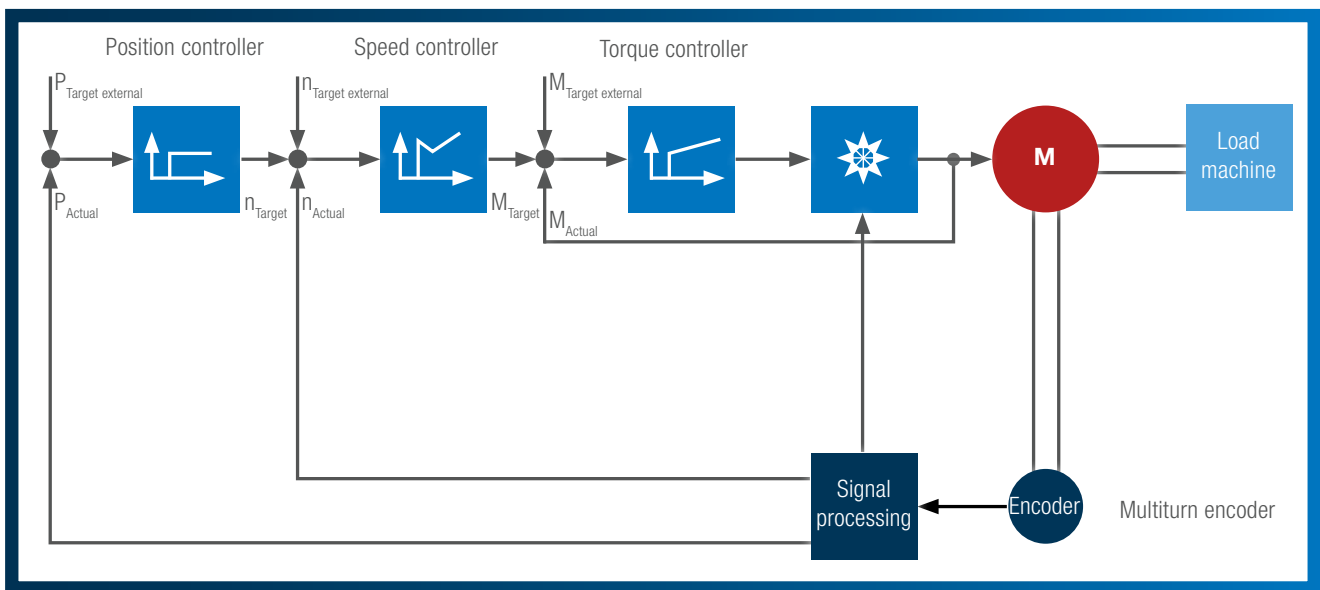

Figure: Cascaded control module



Figure: Control structure within the web-based management

Web-based management

- EL.MOTION components with integrated web server
- Customer-friendly, guided commissioning and servicing via standard web browser
- Using a standard browser on a computer, the following information can be conveniently retrieved from the EL.MOTION network and configured:
 - Network overview
 - Control group overview
 - Parameter view for control components

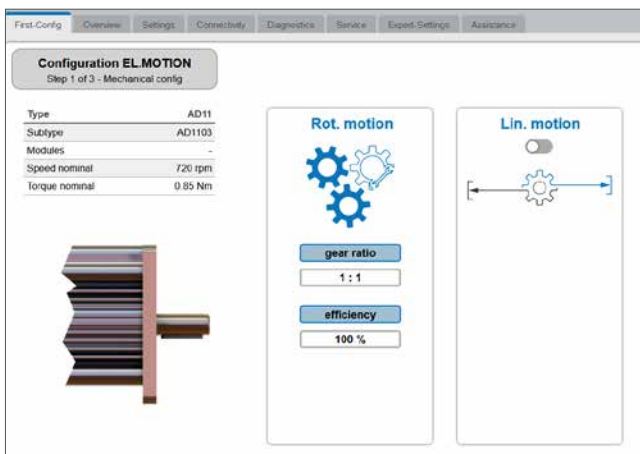

Figure: Guided commissioning

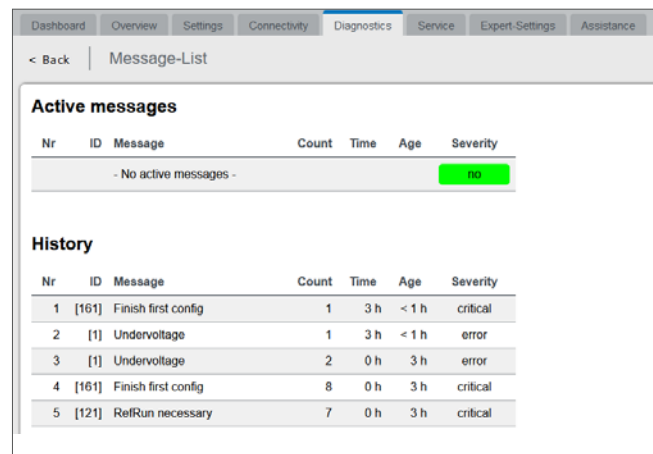

Figure: Active system messages

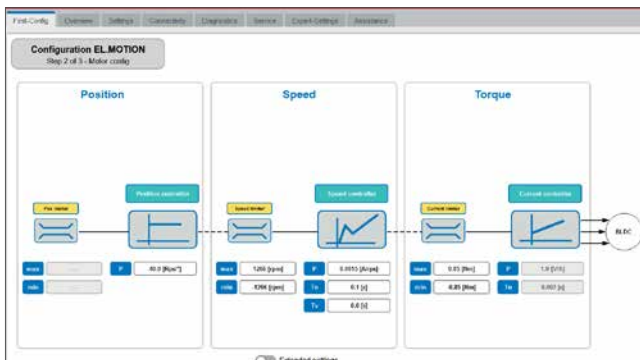

Figure: Parameters for control configuration

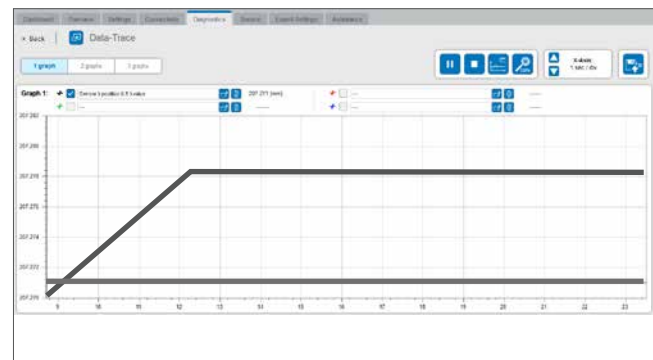

Figure: Data traces

Rotary drive units AD 11 | AD 11 STO

- Decentralized drive technology with integrated control electronics, compact and tailor-made for customer-specific solutions
- Permanently excited synchronous machine (BLDC motor), particularly suitable for applications requiring very smooth running and a long service life
- Constant torque across the entire rotational speed range
- High-resolution multiturn encoder for determination of rotor position and absolute position
- Absolute position detection, even after loss of voltage (without buffer battery)
- High power density and overload capability
- Integrated temperature monitoring
- Two-row slanting ball bearing offers protection for high axial loads
- Integrated fieldbus interface with certified standard protocols
- Simple configuration via web-based management with standard web browser
- Can be combined with all E+L gearbox variants and with the safety brake system
- Optionally with integrated logic card for end position limitation
- Optionally with additional STO (Safe Torque Off) function for functional safety in accordance with EN IEC 61508 with SIL 3 and EN ISO 13849-1 with Category 3 Performance Level d



Rotary drive unit AD 11

Technical data

Nominal voltage	24 V DC
Nominal voltage range	20 V DC to 30 V DC
Nominal current	6.1 A (S1) / 8.0 A (S6)
Nominal torque	1.0 Nm (S1) / 1.2 Nm (S6)
Nominal speed	1000 rpm
Maximum torque	1.3 Nm
Stall torque	1.1 Nm (S1) / 1.3 Nm (S6)
Radial force (distance 24 mm)	200 N
Axial force	3000 N
Constant torque	0.15 Nm/A
Rotor moment of inertia	52 kg/mm ²
Motor weight	2.5 kg
Shaft diameter	14 mm (H7)
Insulation class	F
Resolution, multiturn encoder	12 bits per revolution (4096), 701 revolutions for determination of absolute position
Fieldbus interfaces	EtherNet UDP/IP, EtherNet/IP, Profinet / M8 D-code, 4-pin
Operating voltage	M12 L-code, 5-pin
Limit switch inputs (optional)	4 x digital input / spring terminal
Installation altitude	3000 m above sea level
Ambient temperature	10 °C to +50 °C
Storage temperature	-25 °C to +80 °C
Relative humidity	15 to 95% (non-condensing)
Certifications	CE NRTL certificate CU 72170613 05
Protection class	IP 54



Speed/torque curve AD 11

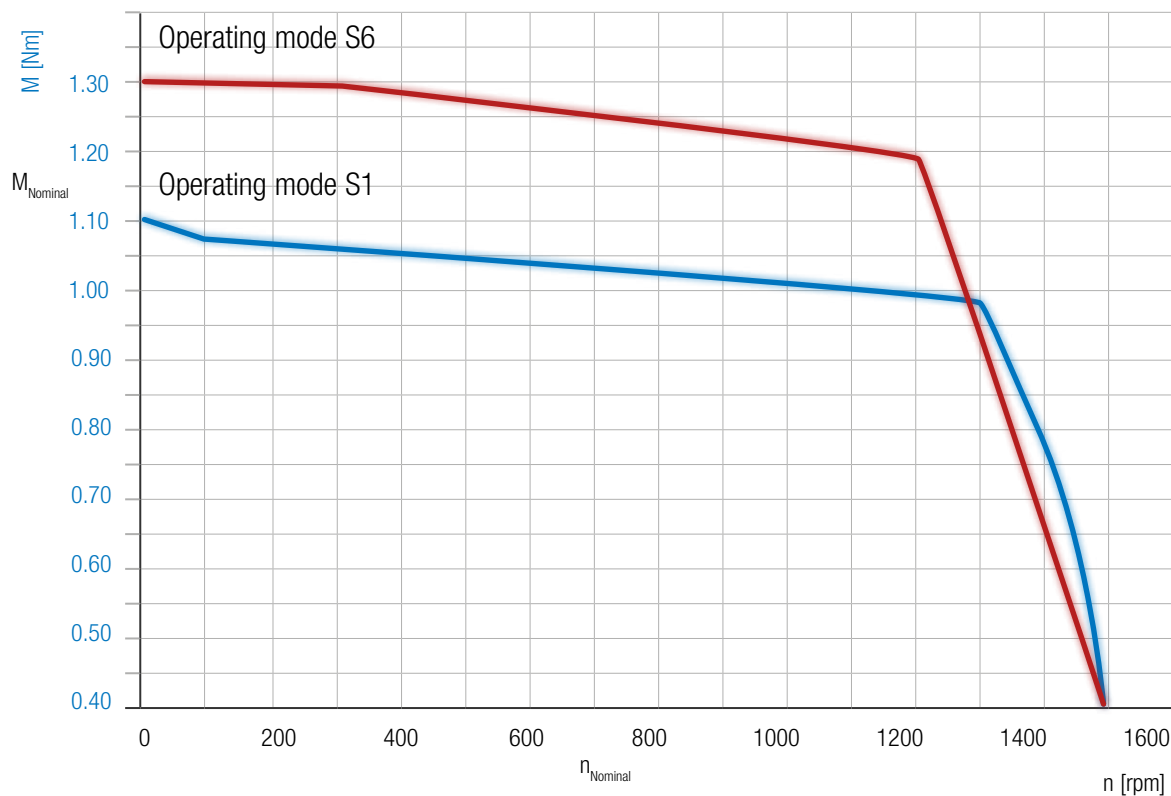

Type	Standard	STO	Standard with limit switch	STO with limit switch
AD 1103	■			
AD 1102		■		
AD 1113			■	
AD 1112				■

STO (Safe Torque Off)

- Safe Torque Off (STO) in accordance with EN 61800-5-2 integrated in the drive
- Suitable for applications with upstream two-channel safety switching devices (Emergency OFF) and for OSSD safety outputs of PLC controllers
- The two-channel architecture (channel A and channel B) of the STO module achieves Category 3 and Performance Level d in accordance with EN ISO 13849-1
- Two-channel interruption of the control pulses to the power stage and therefore of the power supply to the motor as a result of the safe pulse inhibit when the STO safety function is activated

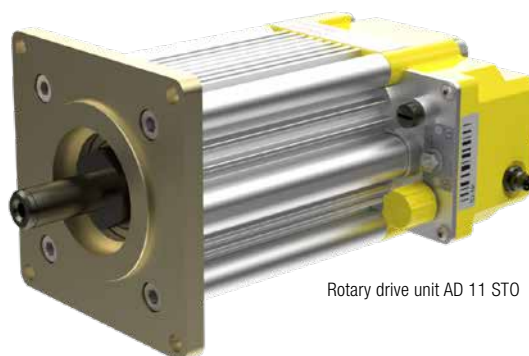

Rotary drive unit AD 11 STO



Rotary drive units AD 12 | AD 12 ST0

- Decentralized drive technology with integrated control electronics, compact and tailor-made for customer-specific solutions
- Permanently excited synchronous machine (BLDC motor), particularly suitable for applications requiring very smooth running and a long service life
- Constant torque across the entire rotational speed range
- High-resolution multiturn encoder for determination of rotor position and absolute position
- Absolute position detection, even after loss of voltage (without buffer battery)
- High power density and overload capability
- Integrated temperature monitoring
- Two-row slanting ball bearing offers protection for high axial loads
- Integrated fieldbus interface with certified standard protocols
- Simple configuration via web-based management with standard web browser
- Can be combined with all E+L gearbox variants and with the safety brake system
- Optionally with integrated logic card for end position limitation
- Optionally with additional STO (Safe Torque Off) function for functional safety in accordance with EN IEC 61508 with SIL 3 and EN ISO 13849-1 with Category 3 Performance Level d



Rotary drive unit AD 12

Technical data

Nominal voltage	24 V DC
Nominal voltage range	20 V DC to 30 V DC
Nominal current	6.6 A (S1) / 8.6 A (S6)
Nominal torque	2.4 Nm (S1) / 3.0 Nm (S6)
Nominal speed	350 rpm
Maximum torque	3.2 Nm
Stall torque	2.5 Nm (S1) / 3.1 Nm (S6)
Radial force (distance 24 mm)	200 N
Axial force	3000 N
Constant torque	0.4 Nm/A
Rotor moment of inertia	106 kg/mm ²
Motor weight	3.4 kg
Shaft diameter	14 mm (H7)
Insulation class	F
Resolution, multiturn encoder	12 bits per revolution (4096), 701 revolutions for determination of absolute position
Fieldbus interfaces	EtherNet UDP/IP, EtherNet/IP, Profinet / M8 D-code, 4-pin
Operating voltage	M12 L-code, 5-pin
Limit switch inputs (optional)	4 x digital input / spring terminal
Installation altitude	3000 m above sea level
Ambient temperature	10 °C to +50 °C
Storage temperature	-25 °C to +80 °C
Relative humidity	15 to 95% (non-condensing)
Certifications	CE NRTL certificate CU 72170613 05
Protection class	IP 54



Speed/torque curve AD 12

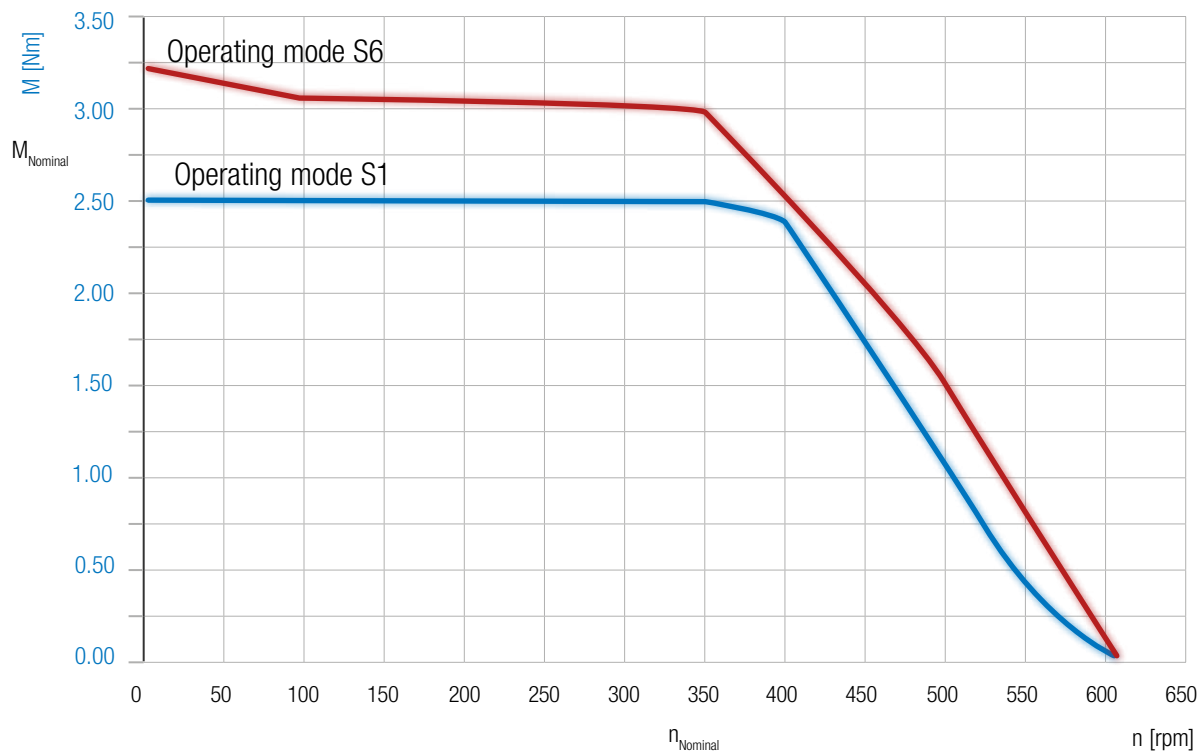

Type	Standard	STO	Standard with limit switch	STO with limit switch
AD 1203	■			
AD 1202		■		
AD 1213			■	
AD 1212				■

STO (Safe Torque Off)

- Safe Torque Off (STO) in accordance with EN 61800-5-2 integrated in the drive
- Suitable for applications with upstream two-channel safety switching devices (Emergency OFF) and for OSSD safety outputs of PLC controllers
- The two-channel architecture (channel A and channel B) of the STO module achieves Category 3 and Performance Level d in accordance with EN ISO 13849-1
- Two-channel interruption of the control pulses to the power stage and therefore of the power supply to the motor as a result of the safe pulse inhibit when the STO safety function is activated

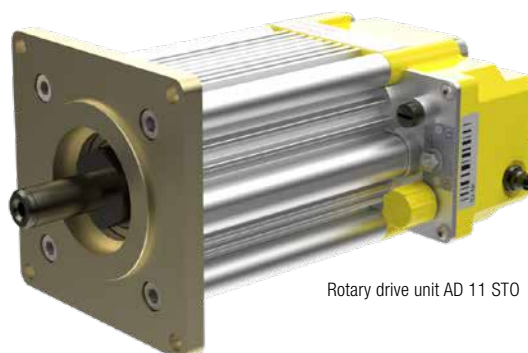

Rotary drive unit AD 14

- Decentralized drive technology with integrated control electronics, compact and tailor-made for customer-specific solutions
- Permanently excited synchronous machine (BLDC motor), particularly suitable for applications requiring very smooth running and a long service life
- Constant torque across the entire rotational speed range
- High-resolution multiturn encoder for determination of rotor position and absolute position
- Absolute position detection, even after loss of voltage (without buffer battery)
- High power density and overload capability
- Integrated temperature monitoring
- Two-row slanting ball bearing offers protection for high axial loads
- Integrated fieldbus interface with certified standard protocols
- Simple configuration via web-based management with standard web browser
- Can be combined with all E+L gearbox variants and with the safety brake system
- Optionally with integrated logic card for end position limitation
- Optionally with additional STO (Safe Torque Off) function for functional safety in accordance with EN IEC 61508 with SIL 3 and EN ISO 13849-1 with Category 3 Performance Level d



Rotary drive unit AD 14

Technical data

Nominal voltage	24 V DC
Nominal voltage range	20 V DC to 30 V DC
Nominal current	6.5 A (S1) / 8.4 A (S6)
Nominal torque	4.0 Nm (S1) / 4.8 Nm (S6)
Nominal speed	225 rpm
Maximum torque	5.0 Nm
Stall torque	4.0 Nm (S1) / 5.0 Nm (S6)
Radial force (distance 24 mm)	200 N
Axial force	3000 N
Constant torque	0.6 Nm/A
Rotor moment of inertia	177 kg/mm ²
Motor weight	4.9 kg
Shaft diameter	14 mm (H7)
Insulation class	F
Resolution, multiturn encoder	12 bits per revolution (4096), 701 revolutions for determination of absolute position
Fieldbus interfaces	EtherNet UDP/IP, EtherNet/IP, Profinet / M8 D-code, 4-pin
Operating voltage	M12 L-code, 5-pin
Limit switch inputs (optional)	4 x digital input / spring terminal
Installation altitude	3000 m above sea level
Ambient temperature	10 °C to +50 °C
Storage temperature	-25 °C to +80 °C
Relative humidity	15 to 95% (non-condensing)
Certifications	CE NRTL certificate CU 72170613 05
Protection class	IP 54



Speed/torque curve AD 14

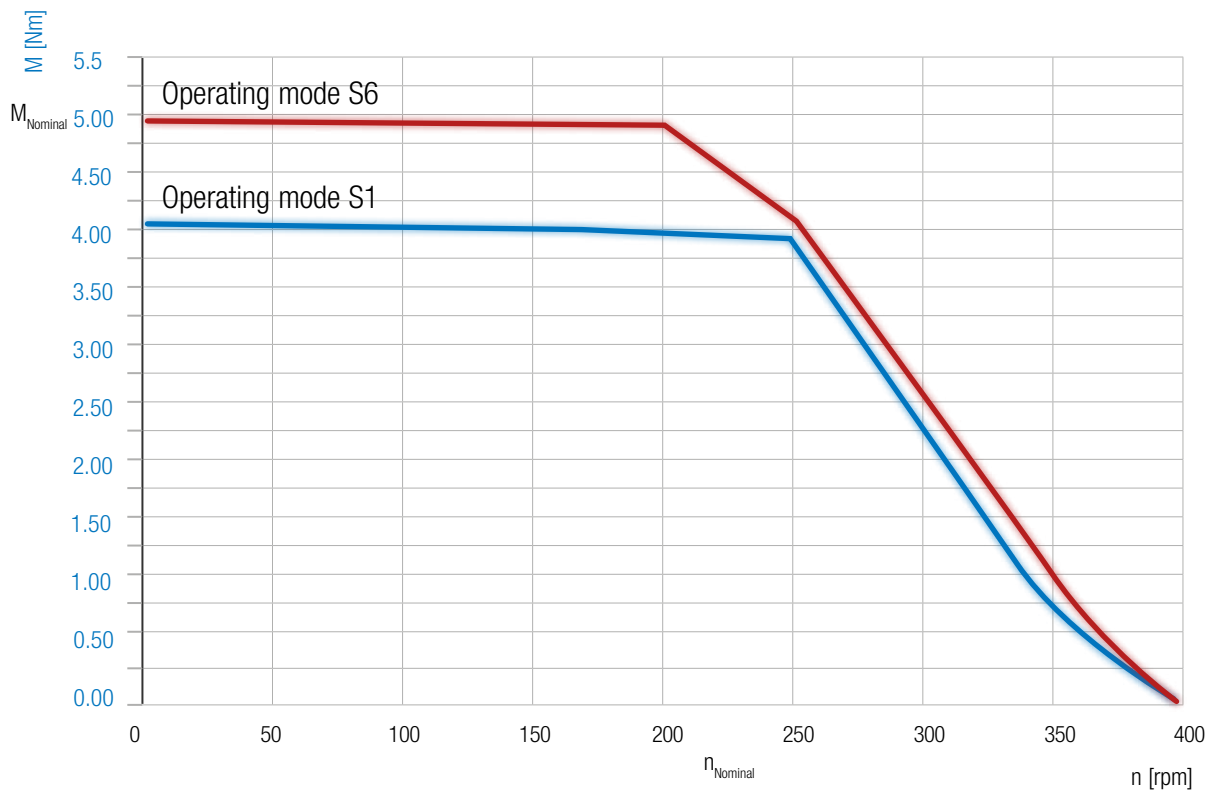

Type	Standard	STO	Standard with limit switch	STO with limit switch
AD 1403	■			
AD 1413			■	

Next-generation E+L MOTORS

Intelligent + pre-integrated drives

Dimension drawing 158972 for AD 11_3 | AD 12_3 | AD 14_3

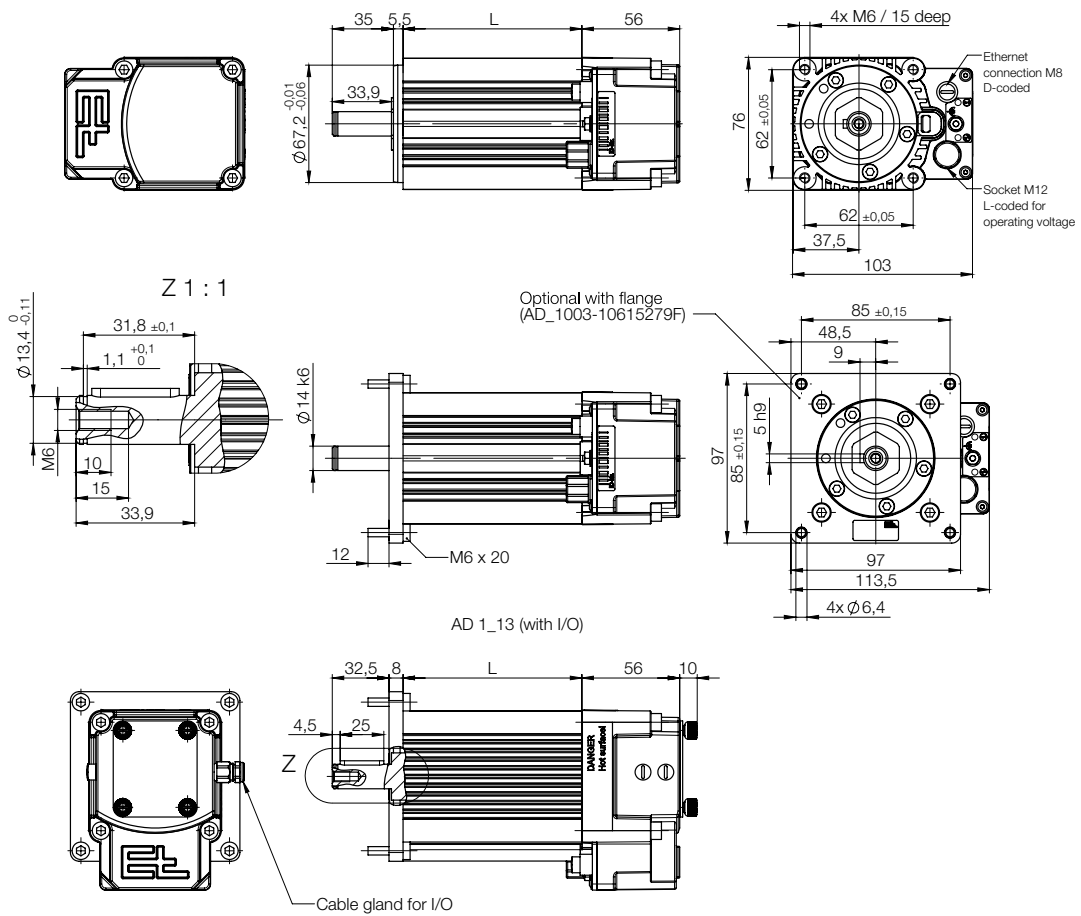

Selection table

Type	Length L	Nominal torque	Nominal speed
AD 11_3	72.3 mm	1 Nm	1000 rpm
AD 12_3	102.3 mm	2.4 Nm	350 rpm
AD 14_3	162.8 mm	4 Nm	225 rpm

Dimension drawing 158974 for AD 11_2 | AD 12_2 (STO)

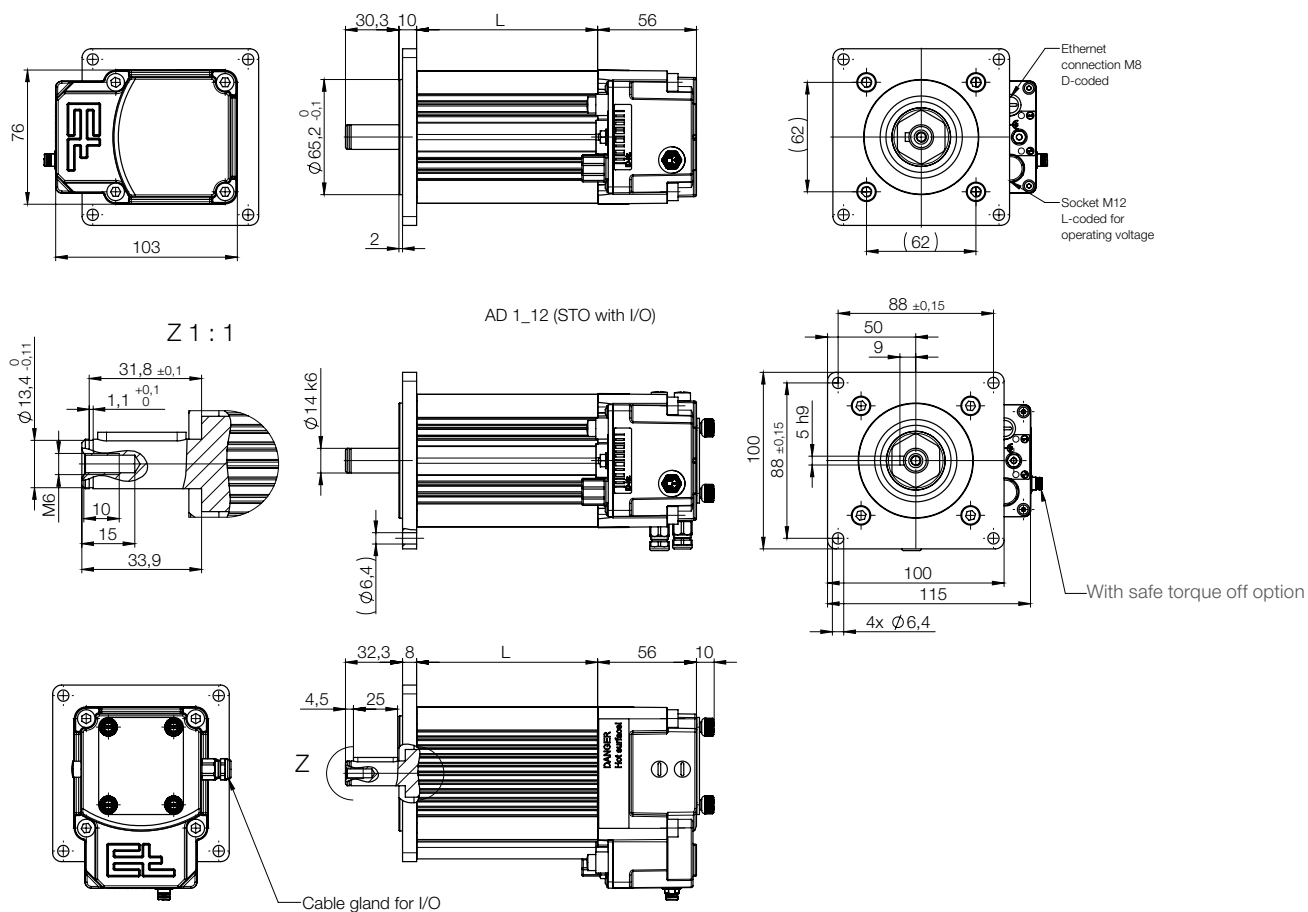

Selection table

Type	Length L	Nominal torque	Nominal speed
AD 11_2	72.3 mm	1 Nm	1000 rpm
AD 12_2	102.3 mm	2.4 Nm	350 rpm

Connection diagram AD 1103 | AD 1203 | AD 1403

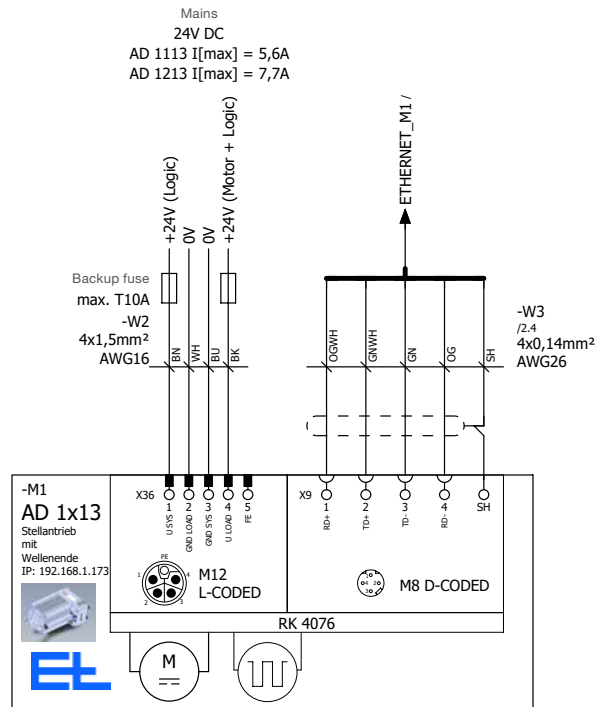

Connection diagram AD 1102 | AD 1202 (STO)

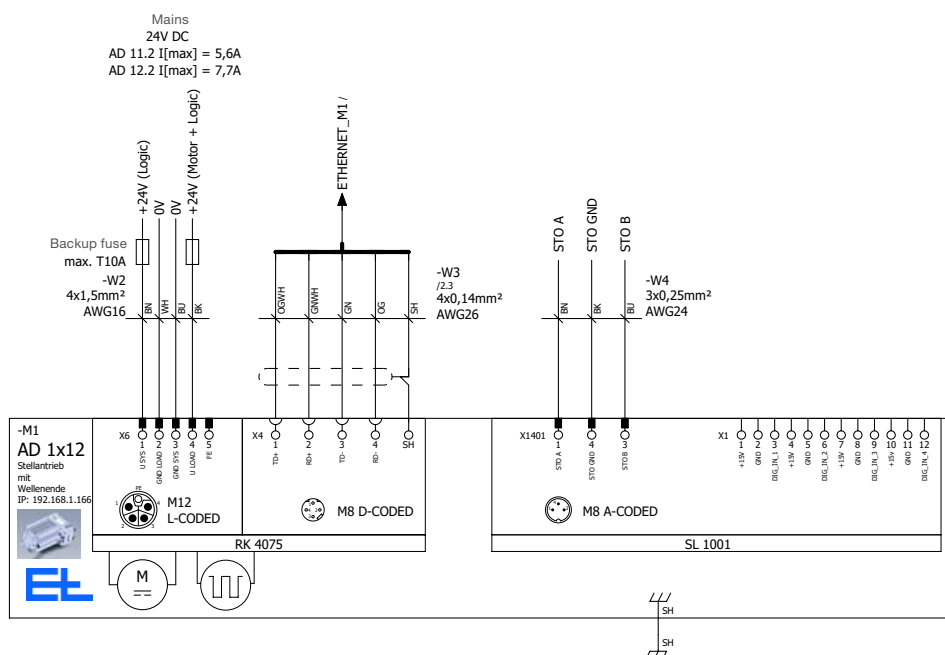

Industry 4.0 – Production meets digitization

In the modern world of automation, industrial Ethernet protocols play a vital role for connection to the higher-level control system. They enable reliable communication and data exchange in real time, and they improve control and monitoring functions. With the wide range of available fieldbus interfaces and protocols, the EL.MOTION drive units can be easily integrated in any control system – whether PLC, industrial computer, or a proprietary controller.



Simplify your processes with Ethernet

- **Flexibility**

Thanks to the integrated protocols, you can quickly and easily adapt your motors to a range of different controller types.

- **Easy integration**

The motors can be seamlessly integrated in existing systems.

- **Programmability**

Configuration and programming are really straightforward via the development environments of the controller manufacturers.

- **Data availability**

All relevant data is saved directly on the device and can be downloaded if required.

Technical data			
	EtherNet/IP	Profinet	POWERLINK
Hardware	Integrated	Integrated	Integrated
Status	Active	Active	Active
Application protocol	CIP	Profinet IO	CANopen
Manufacturer	Rockwell	Siemens	B&R
Cycle time	5 ms	8 ms	2 ms

EtherNet/IP

- Open fieldbus standard based on Ethernet technology and the TCP/IP and UDP/IP stack
- Enables communication in real time with cycle times as low as 5 milliseconds
- Widely used in industrial applications
- Offers seamless integration of equipment

Profinet

- Powerful industrial Ethernet protocol
- Uses UDP/IP and IEEE 802.3 standards and is capable of real-time Ethernet
- Thanks to Conformance Class CC-B a large number of real-time applications can be realized

POWERLINK

- Uncomplicated and flexible protocol that stands out with straightforward integration and easy programmability
- Layout of the protocol enables cycle times as low as 2 milliseconds

EtherNet UDP/IP

- Standard Ethernet protocol requiring no special control technology
- Utilizes a request/response method to exchange data with the control computer
- No description files or special development environments required

Planetary gearboxes

Thanks to the high precision of the helical gearing and the optimized tooth meshing conditions, this design achieves very quiet running, minimal backlash, and high efficiency. We can produce individual, customized motor flanges to maximize flexibility in terms of attachment of the motor to the customer's machine. Thanks to the wide range of planetary gearboxes we have in our portfolio, we can offer our customer the perfect planetary gearbox to best suit their particular application.

Technical data

- High power density and efficiency
- Quiet operation thanks to case-hardened helical gearing
- Minimal backlash ≤ 2.3 arcmin
- Excellent sealing and lubrication system
- Perfect layout of bearing points
- Large selection of sizes and transmission ratios

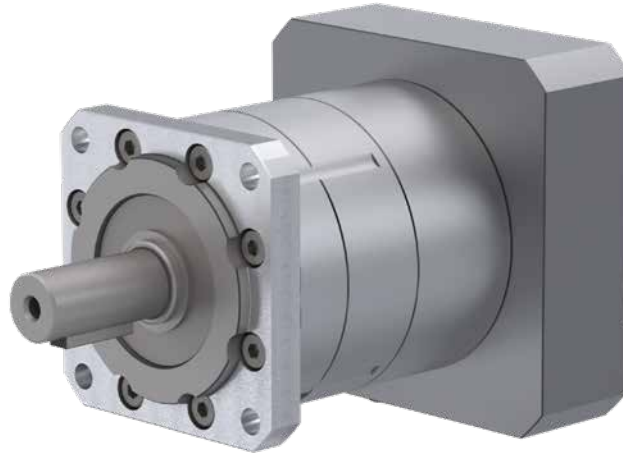

Planetary gearboxes

Technical data									Bore size on the drive side		
Size	Transmission ratio	Nominal torque (drive side)	Max. drive torque	Emergency stop torque	Nominal speed (drive side)	Max. drive speed	Permissible radial force	Permissible axial force	Weight ($\leq \varnothing 14$)	Moment of inertia ($\leq \varnothing 14$)	Torsional rigidity
062	3	35 Nm	55 Nm	80 Nm	3000 rpm	6000 rpm	420 N	520 N	1.0 kg	0.21 kgcm ²	2.3 Nm/arcmin
	4	46 Nm	79 Nm	90 Nm	3000 rpm	6000 rpm	420 N	520 N		0.17 kgcm ²	2.3 Nm/arcmin
	5	46 Nm	79 Nm	90 Nm	3000 rpm	6000 rpm	420 N	520 N		0.16 kgcm ²	2.3 Nm/arcmin
	8	46 Nm	76 Nm	90 Nm	3000 rpm	6000 rpm	420 N	520 N		0.14 kgcm ²	2.3 Nm/arcmin
	9	35 Nm	55 Nm	80 Nm	3000 rpm	6000 rpm	420 N	520 N		0.14 kgcm ²	2.3 Nm/arcmin
	10	35 Nm	55 Nm	80 Nm	3000 rpm	6000 rpm	420 N	520 N		0.14 kgcm ²	2.3 Nm/arcmin
	12	35 Nm	46 Nm	80 Nm	3000 rpm	6000 rpm	420 N	520 N	1.6 kg	0.16 kgcm ²	2.3 Nm/arcmin
	15	35 Nm	46 Nm	80 Nm	3000 rpm	6000 rpm	420 N	520 N		0.15 kgcm ²	2.3 Nm/arcmin
	16	46 Nm	66 Nm	90 Nm	3000 rpm	6000 rpm	420 N	520 N		0.16 kgcm ²	2.3 Nm/arcmin
	20	46 Nm	66 Nm	90 Nm	3000 rpm	6000 rpm	420 N	520 N		0.15 kgcm ²	2.3 Nm/arcmin
	25	46 Nm	66 Nm	90 Nm	3000 rpm	6000 rpm	420 N	520 N		0.15 kgcm ²	2.3 Nm/arcmin
	32	46 Nm	66 Nm	90 Nm	3000 rpm	6000 rpm	420 N	520 N		0.16 kgcm ²	2.3 Nm/arcmin
	40	46 Nm	66 Nm	90 Nm	3000 rpm	6000 rpm	420 N	520 N		0.14 kgcm ²	2.3 Nm/arcmin
	50	46 Nm	66 Nm	90 Nm	3000 rpm	6000 rpm	420 N	520 N		0.14 kgcm ²	2.3 Nm/arcmin
	80	46 Nm	66 Nm	90 Nm	3000 rpm	6000 rpm	420 N	520 N		0.14 kgcm ²	2.3 Nm/arcmin
	100	35 Nm	46 Nm	80 Nm	3000 rpm	6000 rpm	420 N	520 N		0.14 kgcm ²	2.3 Nm/arcmin

Dimension drawing for AD drive with planetary gearbox

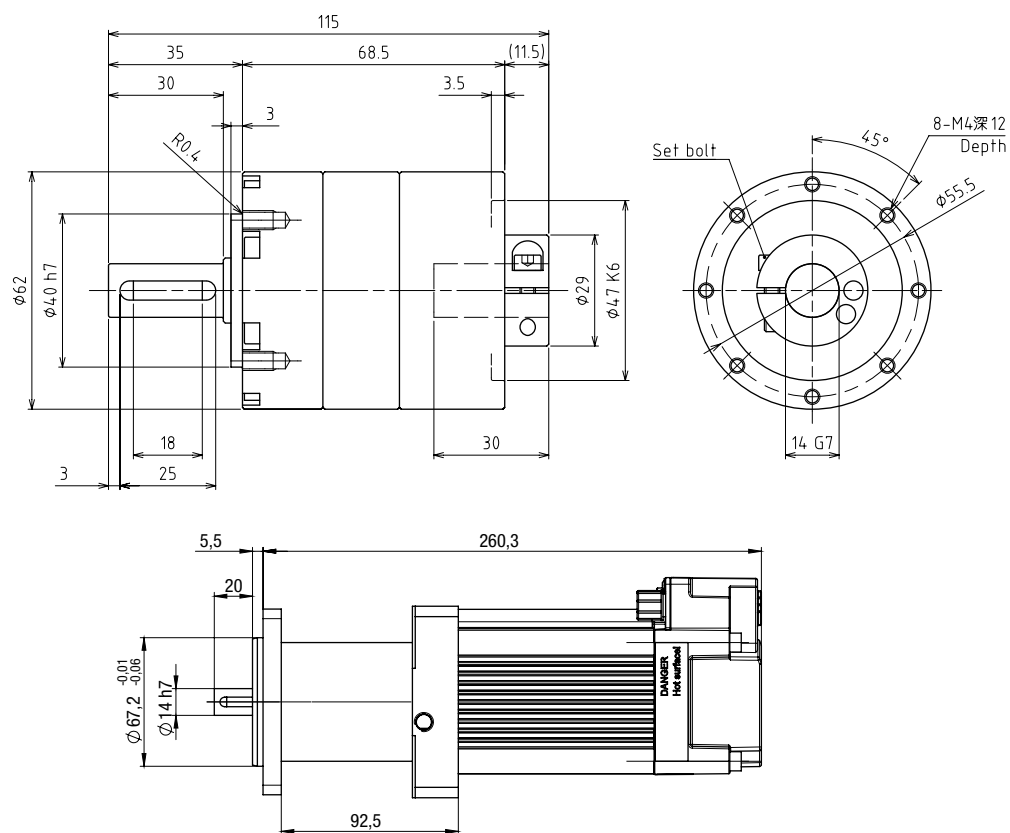

Technical data

Size	Stages *1	Input bore E*2	Dimensions																
			L	LR	S	ST	Y	Q	QK	QN	QM	WxU	T	D	LB	LE	LA	LZ	X
062	1-stage	$\leq \phi 14$	*3	35	14	M5	12	30	25	3	18	5x3	5	62	40	3	52	M5	8
	2-stage	$\leq \phi 14$																	



Rotary drive unit AD
with planetary gearbox

Angular gearboxes

Angular gearboxes offer our customers unique advantages in terms of mechanical integration and positioning accuracy and are therefore suitable for use in almost all machine applications. Our single-stage angular gearbox is available with a range of different transmission ratios, so it can be individually matched to the specific requirements of the application. The units are lubricated for life, meaning that the gearbox is practically maintenance-free under normal operating conditions. We can produce individual, customized adaptation solutions to maximize flexibility in terms of integration of the drive unit in the customer's machine.



Angular gearboxes

Technical data

- Single-stage angular gearbox with transmission ratios of 5:1, 8:1, 10:1, and 15:1
- Compact, stable design for maximum performance with small dimensions and low weight
- Lubricated for life and therefore maintenance-free
- Energy savings thanks to high efficiency of up to 96%
- Customer-specific flange adaptations are possible
- High torsional rigidity at the output shaft

Technical data

Size	DE-PL55
Transmission ratio	5/8/10/15
Nominal torque	35 Nm
Acceleration	Max. 53 Nm
Emergency stop torque	70 Nm
Speed at the drive	Max. 6000 rpm
Nominal speed at the drive with $i = 5/8$	3100 rpm
Nominal speed at the drive with $i = 10/15$	3800 rpm
Backlash	<7 arcmin
Torsional rigidity at the output	2.5 Nm/arcmin
Radial force	2200 N
Axial force	1100 N
Efficiency under full load	>96%
Running noise ($n_1 = 3000$ rpm)	>66 dB(A)
Weight approx.	2.6 kg
Service life	>30,000 h S5 load spectrum as the design basis
Lubrication	Lubricated for life, enclosed system
Mounting positions	Any
Operating temperature	-10 °C to +90 °C
Paint finish	Undercoat RAL 9005 – Jet Black
Ex protection	Explosion-proof gearbox available on request
Protection class	IP 64

Dimension drawing for AD drive with angular gearbox

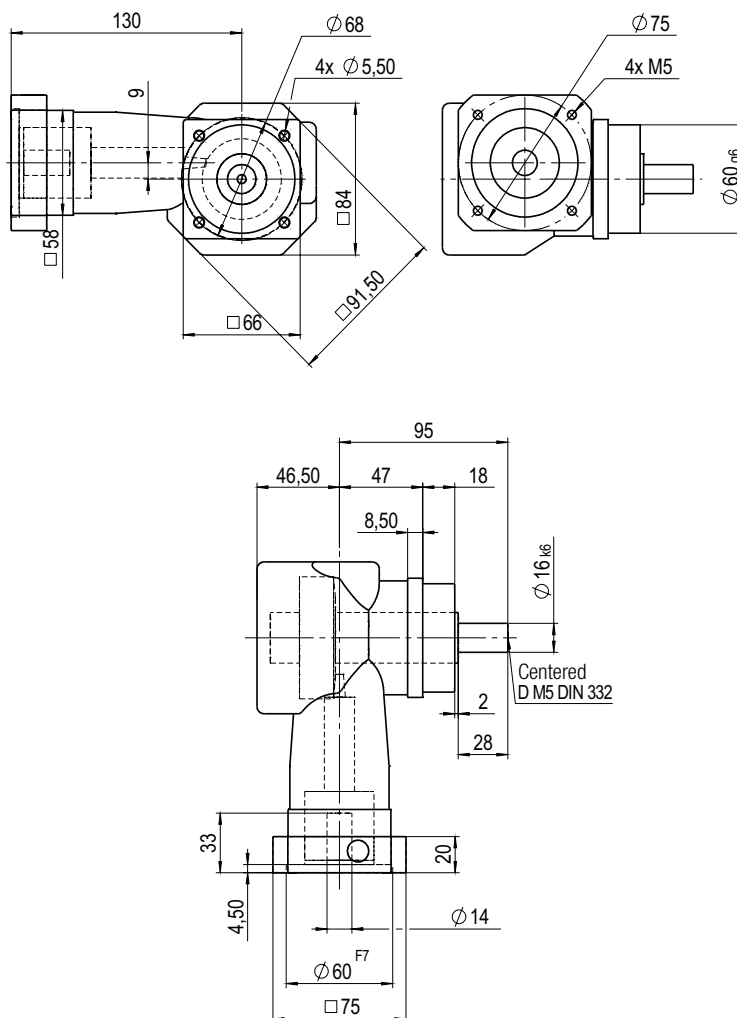

Technical data

Size	a	b	x	0	e	f ₁	g ₁	t ₁	g ₂	t ₂	ø k	u ₂	ø v ₂	ø w _{2g6}
DE-PL55	84	91.5	47	9	58	130	4.5	20	18	8.5	5.5	66	68	60

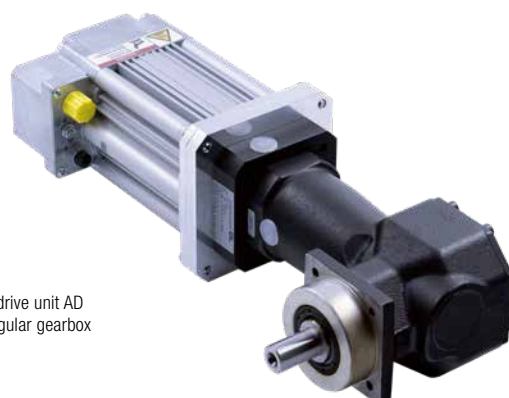

Rotary drive unit AD
with angular gearbox

Solid and hollow shaft gearboxes

Solid and hollow shaft gearboxes offer our customers unique advantages in terms of mechanical integration and positioning accuracy and are therefore suitable for use in almost all machine applications. Our single-stage angular gearbox is available with a range of different transmission ratios, so it can be individually matched to the specific requirements of the application.

The units are lubricated for life, meaning that the gearbox is practically maintenance-free under normal operating conditions. We can produce individual, customized adaptation solutions to maximize flexibility in terms of integration of the drive unit in the customer's machine.

Technical data

- Version available with solid and hollow shaft
- Single-stage angular gearbox with transmission ratios from 3:1 to 15:1
- Compact, stable design for maximum performance with compact dimensions and low weight
- Lubricated for life and therefore maintenance-free
- Energy savings thanks to high efficiency of up to 96% with high coupling stiffness
- Customer-specific flange adaptations are possible



Solid and hollow shaft gearboxes

Technical data	
Size	D55
Transmission ratio	5/8/10
Nominal torque	35 Nm
Acceleration	Max. 53 Nm
Emergency stop torque	70 Nm
Speed at the drive	Max. 8000 rpm
Nominal speed at the drive with $i = 3/4/5$	2100 rpm
Nominal speed at the drive with $i = 6/8/10$	3200 rpm
Backlash	<5 arcmin
Torsional rigidity at the output	2.1 Nm/arcmin
Radial force	3300 N
Axial force	1650 N
Efficiency under full load	>96%
Running noise ($n_1 = 3000$ rpm)	>66 dB(A)
Weight approx.	3.5 kg
Service life	>30,000 h S5 load spectrum as the design basis
Lubrication	Lubricated for life, enclosed system
Mounting positions	Any
Operating temperature	-10 °C to +90 °C
Paint finish	Undercoat RAL 9005 – Jet Black
Protection class	IP 64

Dimension drawing for AD drive with solid and hollow shaft gearbox

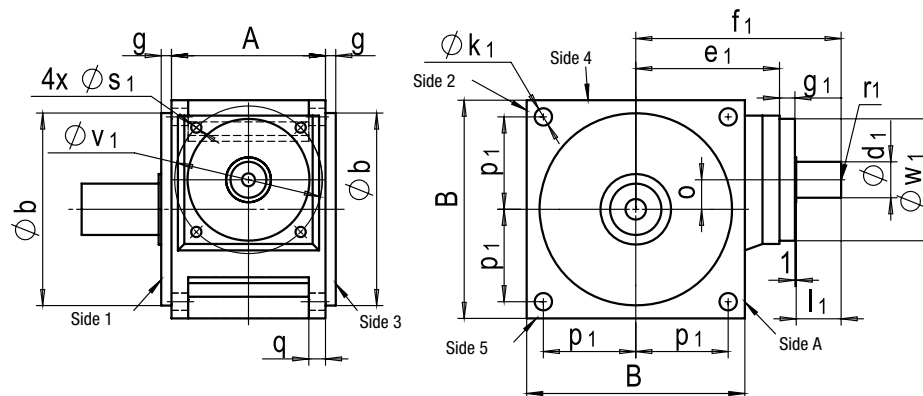

Modular safety brake system ROBA-topstop

The EL.MOTION drive systems are not only suitable for use in standard applications, but thanks to their modular system concept they can also be easily expanded to meet special requirements in a wide range of applications. Particularly in the case of vertical axes, the risk of a load dropping down cannot be ruled out, resulting in a safety risk for anyone in the danger area. This risk must be minimized with the aid of additional measures. By using the ROBA-topstop safety brake, hazardous situations can be safely mitigated in accordance with the applicable standards, ensuring that the load is safely and reliably held even if the drive unit is e.g. removed for maintenance work.

Technical data

- Attachment on the A-bearing side
- Modular safety system
- Self-sufficient, independent brake system
- Safe stop of the axis in any position, even after disassembly of the servo motor e.g. during machine maintenance
- Optimized brake system for vertical axes and for handling of heavy weights
- Long service life even with frequent emergency stop braking interventions
- Operating status (engaged/disengaged) signaled via integrated status monitoring
- Short, compact design
- Low rotational moment of inertia
- Minimal internal heat build-up even with a duty cycle of 100%



ROBA-topstop brake

Technical data

Braking torque Nm	12 Nm
Electrical power	16 W / 66 W
Operating voltage	12 V / 24 V excitation voltage
Dimensions	100 mm x 80 mm x 100 mm
Shaft diameter, output side	14 mm x 30 mm
Mass moment of inertia	0.9 kgm ²
Weight	4.75 kg
Radial force F_r	250 N / max. 6000 rpm
Insulation class	F
Protection class	IP 54
Ambient temperature	-20 °C to 40 °C
Certifications	Directive 2006/42/EC – Machinery Directive CSA LR 108927-1 UL 508 (Edition 17)

ROBA-switch 24 V DC

- Operation of the consumer with overexcitation
- Integrated shutdown on the DC side
- Analog output for status feedback
- UL certification



ROBA-switch 24 V DC

Technical data

Input voltage	24 V DC
Output current	Max. 5 A
Excitation current	Max. 10 A
Device fuse	12.5 A
Protection class	IP 00 for control cabinet installation
Ambient temperature	-25 °C to 70 °C
Nominal cross-section of connection terminals	1.5 mm ² / 0.5 mm
Power-free control input	10 mA

Expansion unit for easy machine integration

The expansion unit acts as a connecting link between the hardware on the customer's side and the EL.MOTION drive units. It can be used to transmit commands or values from an external controller, e.g. a PLC, from switch contacts, or from analog signals. Corresponding messages can also be sent out via outputs. Users can freely select the configuration of the inputs and outputs (Multi I/O). The expansion unit can be integrated as a DIN rail module in the control cabinet that houses the customer's control system.

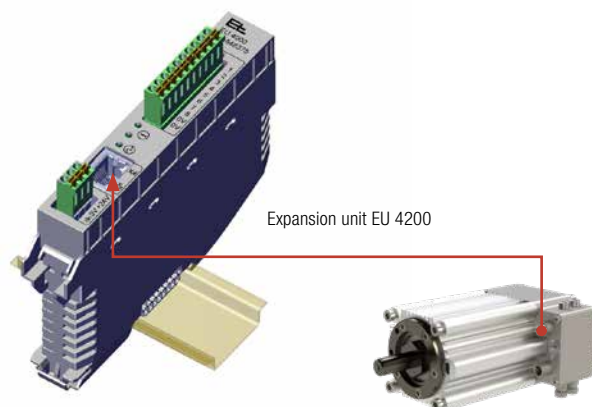

Multifunctional I/O module

Digital inputs

- Start, Stop, Block motor
- Speed, 2 levels
- Rotation clockwise/counterclockwise
- Encoder A/B synchronization

Analog inputs

- Analog setpoint value from the customer's side
- Analog speed variables

Digital outputs

- Positions feedback
- End positions
- Speed levels
- Motor status messages
- Status message

Analog output

- Position output values

Technical data

Operating voltage, nominal value	24 V DC
Operating voltage, nominal range	20 V DC to 30 V DC (ripple included)
Current consumption	50 mA (without PoE) Max. 350 mA (with PoE)
Ethernet interface	RJ 45 socket, 100 Mbit/s, potential-free
Ethernet PoE port (IEEE 802.3af)	RJ45 PSE, 100 Mbit/s, class 2 (7 W)
Ambient temperature	10 °C to 50 °C
Storage temperature	-25 °C to 80 °C
Relative humidity	15 to 95% (non-condensing)
Installation altitude	0 to 2000 m above sea level
Protection class	IP 20
Certificate	UL 61010-1 CAN/CSA -C22.2 61010-1-12
Fastening	DIN rail: DIN EN 60715:2018-07
Weight	Approx. 80 g
Dimensions (L x W x H)	121 x 23 x 94 mm

Functions

Terminal X5	Input				Output			
	Digital	Analog	Counter	Interrupt	Power	Digital	Analog	Counter
						Fast		
1	x	x	Encoder A	-	x	-	-	-
2	x	x	Encoder B	-	x	-	-	-
3	x	x	-	x	x	x	-	Compare
4	x	x	-	x	x	x	-	Compare
5	x	x	Capture	-	x	x	-	Compare
6	x	x	Capture	-	x	x	-	Compare
7	x	x	-	x	x	-	-	-
8	x		-	x	x	-	x	-
9					GND			
10					GND			

Linear drive unit AG 72

- Linear actuating drive with permanently excited synchronous machine (BLDC motor) in U-shaped design, particularly suitable for applications requiring very smooth running and a long service life
- High-resolution multiturn encoder for determination of rotor position and absolute position
- Absolute position detection, even after loss of voltage (without buffer battery)
- Space-saving design thanks to integrated control electronics
- High power density and overload capability
- Integrated temperature monitoring
- Simple configuration via web-based management with standard web browser



Linear drive unit AG 72

Selection table

Type	Nominal actuating travel	Nominal actuating force
AG 7213	±6 mm	250 N
AG 7223	± 12 mm	250 N
AG 7233	± 15 mm	250 N
AG 7243	± 25 mm	250 N
AG 7263	± 50 mm	250 N

Technical data

Positioning accuracy	0.05 mm
Nominal actuating travel	See selection table
Nominal actuating speed	Max. 60 mm/s
Nominal actuating force	250 N
Ambient temperature	+10 °C to +60 °C
Storage temperature	-20 °C to +80 °C
Relative humidity	15 to 95% (non-condensing)
Operating voltage	24 V DC M12 L-code, 5-pin
Current consumption	Max. 2.5 A DC
Fieldbus interfaces	EtherNet UDP/IP; EtherNet/IP; Profinet; POWERLINK; M8 D-code, 4-pin
Certifications	Declaration of incorporation in accordance with Machinery Directive 2006/42/EC NRTL certificate CU
Protection class	IP 54



Dimension drawing for AG 72

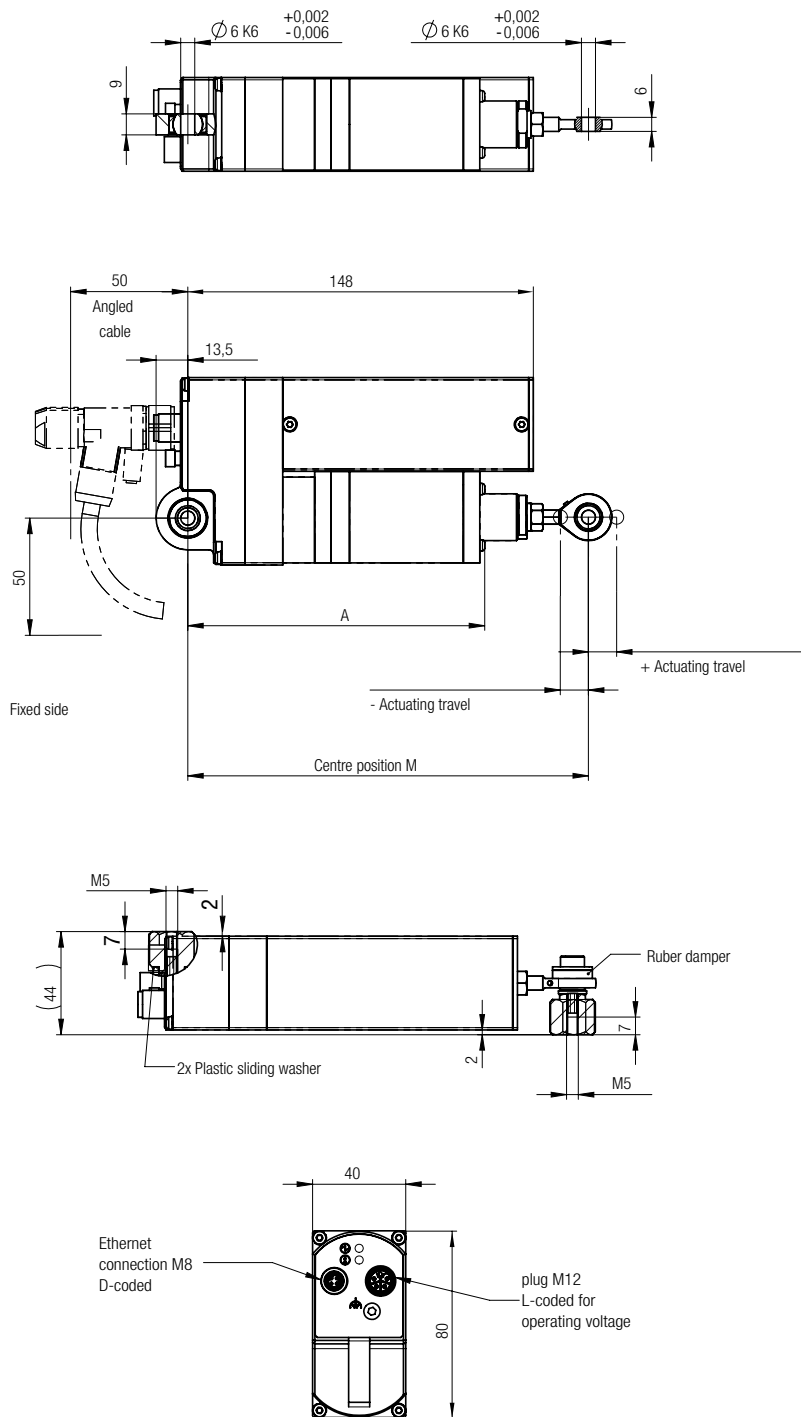

Linear drive units AG 91/93

- Linear actuating drive with permanently excited synchronous machine (BLDC motor), particularly suitable for applications requiring very smooth running and a long service life
- Integrated digital controller with position, speed, and current controller for highest control quality
- High-resolution multiturn encoder for determination of rotor position and absolute position
- Absolute position detection, even after loss of voltage (without buffer battery)
- Space-saving design thanks to integrated control electronics
- Integrated fieldbus interfaces EtherNet UDP/IP, EtherNet/IP, Profinet, POWERLINK
- High power density and overload capability
- Integrated temperature monitoring
- Maintenance-free thanks to the use of high-grade mechanical components
- Customer-friendly guided commissioning and servicing functions via web-based management
- Optionally with functional safety in accordance with EN IEC 61508 with SIL3 and EN ISO 13849-1 in Performance Level d, category 3



Linear drive unit AG 91/93

Selection table

Type	Nominal actuating travel	Nominal actuating force
AG 9103	± 25 mm	1000 N
AG 9113	± 50 mm	1000 N
AG 9123	± 75 mm	1000 N
AG 9133	± 100 mm	1000 N
AG 9313	± 50 mm	3000 N
AG 9333	± 100 mm	3000 N
AG 9343	± 150 mm	3000 N
AG 9353	± 200 mm	3000 N

Technical data

Positioning accuracy	0.05 mm
Nominal actuating travel	See selection table
Nominal actuating speed	Max. 30 mm/s (AG 93), max. 60 mm/s (AG 91)
Nominal actuating force	1000 N (AG 91), 3000 N (AG 93)
Resolution, multiturn encoder	12 bits per revolution (4096)
Ambient temperature	+10 °C to +60 °C
Storage temperature	-20 °C to +80 °C
Relative humidity	15 to 95% (non-condensing)
Operating voltage	24 V DC M12 L-code, 5-pin
Current consumption	Max. 6.2 A DC Max. 8.3 A DC
Fieldbus interfaces	EtherNet UDP/IP; EtherNet/IP; Profinet; POWERLINK; M8 D-code, 4-pin
Certifications	Declaration of incorporation in accordance with Machinery Directive 2006/42/EC NRTL certificate CU 72170613 04
Protection class	IP 54



Dimension drawing AG 91/93

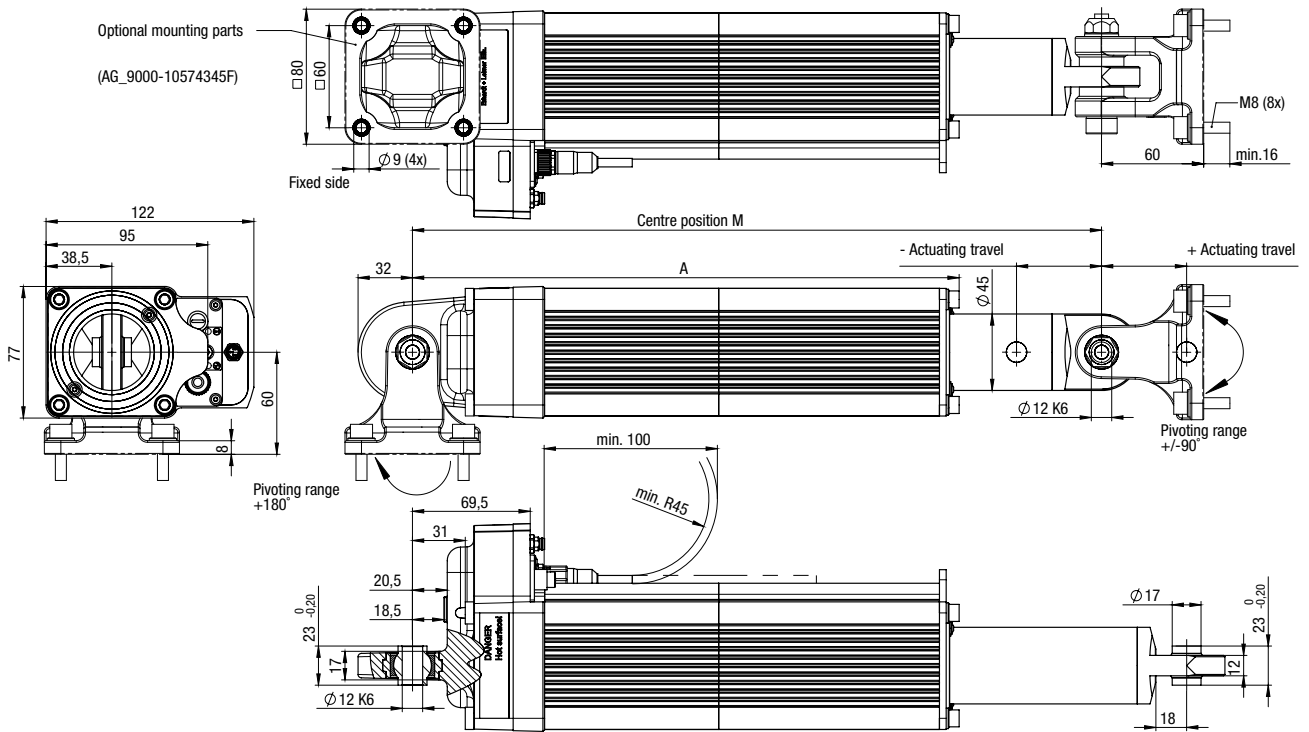

Linear drive units AG 91/93 STO

- Linear actuating drive with permanently excited synchronous machine (BLDC motor), particularly suitable for applications requiring very smooth running and a long service life
- Integrated digital controller with position, speed, and current controller for highest quality of positioning control
- High-resolution multiturn encoder for determination of rotor position and absolute position
- Absolute position detection, even after loss of voltage (without buffer battery)
- Space-saving design thanks to integrated control electronics
- Integrated fieldbus interfaces EtherNet UDP/IP, EtherNet/IP, Profinet, POWERLINK
- High power density and overload capability
- Integrated temperature monitoring
- Maintenance-free thanks to the use of high-grade mechanical components
- Customer-friendly guided commissioning and servicing functions via web-based management
- STO functional safety in accordance with EN IEC 61508 with SIL3 and EN ISO 13849-1 in Performance Level d, Category 3



Linear drive unit AG 93.2

Standards	Category	Description
IEC 61508-1: 2010 IEC 61508-2: 2010	SIL 3	Functional safety of electrical/electronic/programmable electronic safety-related systems Part 1: General requirements Teil 2: Requirements for electrical/electronic/programmable electronic safety-related systems
IEC 61508-5-2: 2016	SIL 3	Adjustable speed electrical power drive systems Part 5-2: Safety requirements - Functional
IEC 62061: 2021	SIL 3	Safety of machinery - Functional safety of safety-related control systems
ISO 13849-1: 2015 ISO 13849-2: 2012	PL d	Safety of machinery - Safety-related parts of control systems Part 1: General principles for design Part 2: Validation

Selection table		
Type	Nominal actuating travel	Nominal actuating force
AG 9102	± 25 mm	1000 N
AG 9112	± 50 mm	1000 N
AG 9122	± 75 mm	1000 N
AG 9132	± 100 mm	1000 N
AG 9312	± 50 mm	3000 N
AG 9332	± 100 mm	3000 N
AG 9342	± 150 mm	3000 N
AG 9352	± 200 mm	3000 N

Technical data	
Positioning accuracy	0.05 mm
Operating voltage	24 V DC
Nominal current	5.6 A (AG 91.2) 7.7 A (AG 93.2)
Nominal actuating force	1000 N (AG 91) / 3000 N (AG 93)
Nominal actuating speed	Max. 30 mm/s (AG 93.2), max. 60 mm/s (AG 91.2)
Insulation class	F
Resolution, multiturn encoder	12 bits per revolution (4096 increments)
Fieldbus interfaces	EtherNet UDP/IP; EtherNet/IP; Profinet; POWERLINK
Electrical connections	Communication: M8 D-code, 4-pin Operating voltage: M12 L-code, 5-pin STO: M8 A-code, 3-pin
Installation altitude	Max. 3000 m above sea level
Ambient temperature	+10 °C to +60 °C
Storage temperature	-20 °C to +80 °C
Humidity	15 to 95% (non-condensing)
Certifications	Declaration of incorporation in accordance with Machinery Directive 2006/42/EC NRTL certificate CU 72170613 04
Protection class	IP 54



Dimension drawing for AG 91/93 STO

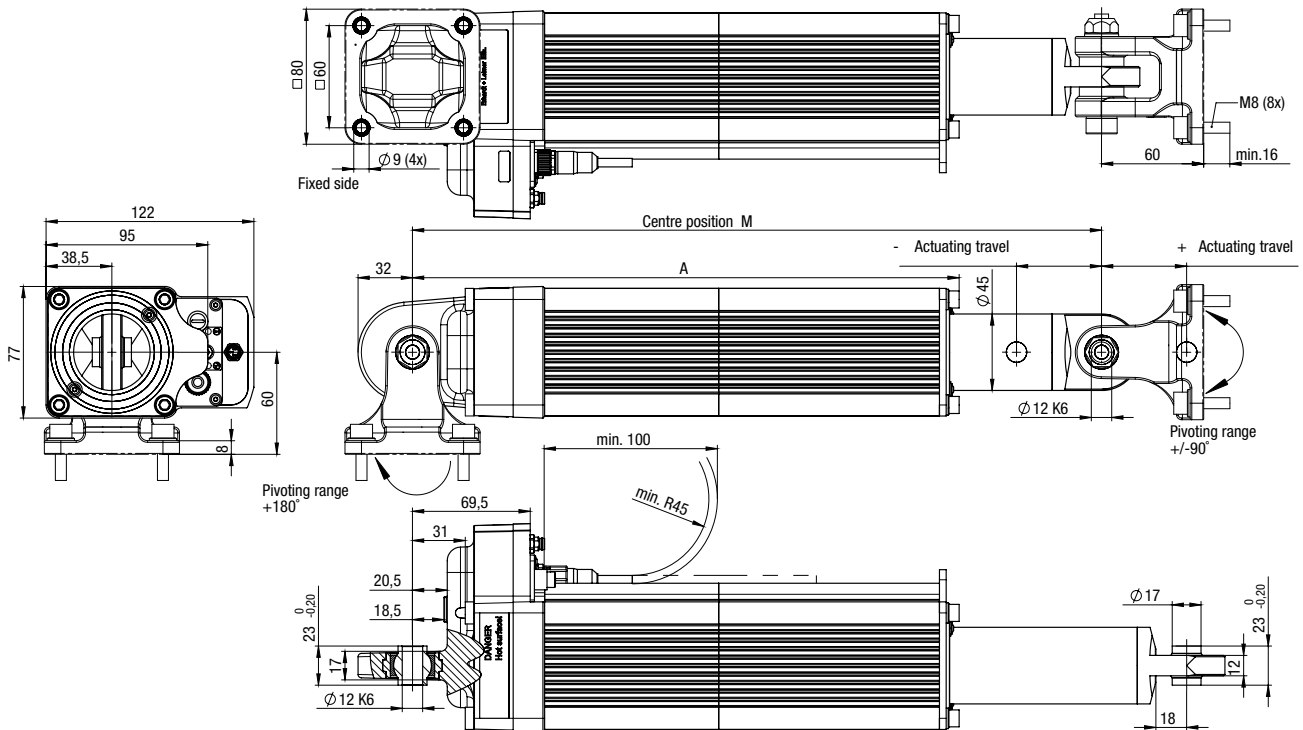

Linear drive units AG 91/93 STO

Type	Nominal actuating travel	Nominal actuating force	M	A
AG 9102	± 25 mm	1000 N	285 mm	227 mm
AG 9112	± 50 mm	1000 N	360 mm	277 mm
AG 9122	± 75 mm	1000 N	435 mm	327 mm
AG 9132	± 100 mm	1000 N	510 mm	377 mm
AG 9312	± 50 mm	3000 N	390 mm	307 mm
AG 9332	± 100 mm	3000 N	540 mm	407 mm
AG 9342	± 150 mm	3000 N	745 mm	568 mm
AG 9352	± 200 mm	3000 N	895 mm	668 mm

Linear drive unit AG 96

- Linear actuating drive with permanently excited synchronous machine (BLDC motor), particularly suitable for applications requiring very smooth running and a long service life
- Integrated digital controller with position, speed, and current controller for highest quality of positioning control
- High-resolution multiturn encoder for determination of rotor position and absolute position
- Absolute position detection, even after loss of voltage (without buffer battery)
- Space-saving design thanks to integrated control electronics
- Integrated fieldbus interfaces EtherNet/IP, Profinet, POWERLINK
- High power density and overload capability
- Integrated temperature monitoring
- Maintenance-free thanks to the use of high-grade mechanical components
- Customer-friendly guided commissioning and servicing functions via web-based management
- Optionally with functional safety in accordance with EN IEC 61508 with SIL3 and EN ISO 13849-1 in Performance Level d, category 3



Linear drive unit AG 96

Selection table

Type	Nominal actuating travel	Nominal actuating force
AG 9613	± 50 mm	5500 N
AG 9633	± 100 mm	5500 N
AG 9643	± 150 mm	5500 N
AG 9653	± 200 mm	5500 N

Technical data

Positioning accuracy	0.05 mm
Nominal actuating travel	See selection table
Nominal actuating speed	Max. 15 mm/s
Nominal actuating force	5500 N
Ambient temperature	+10 °C to +60 °C
Storage temperature	-20 °C to +80 °C
Relative humidity	15 to 95% (non-condensing)
Operating voltage	24 V DC M12 L-code, 5-pin
Current consumption	Max. 8.8 A DC
Fieldbus interfaces	EtherNet UDP/IP; EtherNet/IP; Profinet; POWERLINK; M8 D-code, 4-pin
Certifications	Declaration of incorporation in accordance with Machinery Directive 2006/42/EC NRTL certificate CU
Protection class	IP 54



Dimension drawing for AG 96

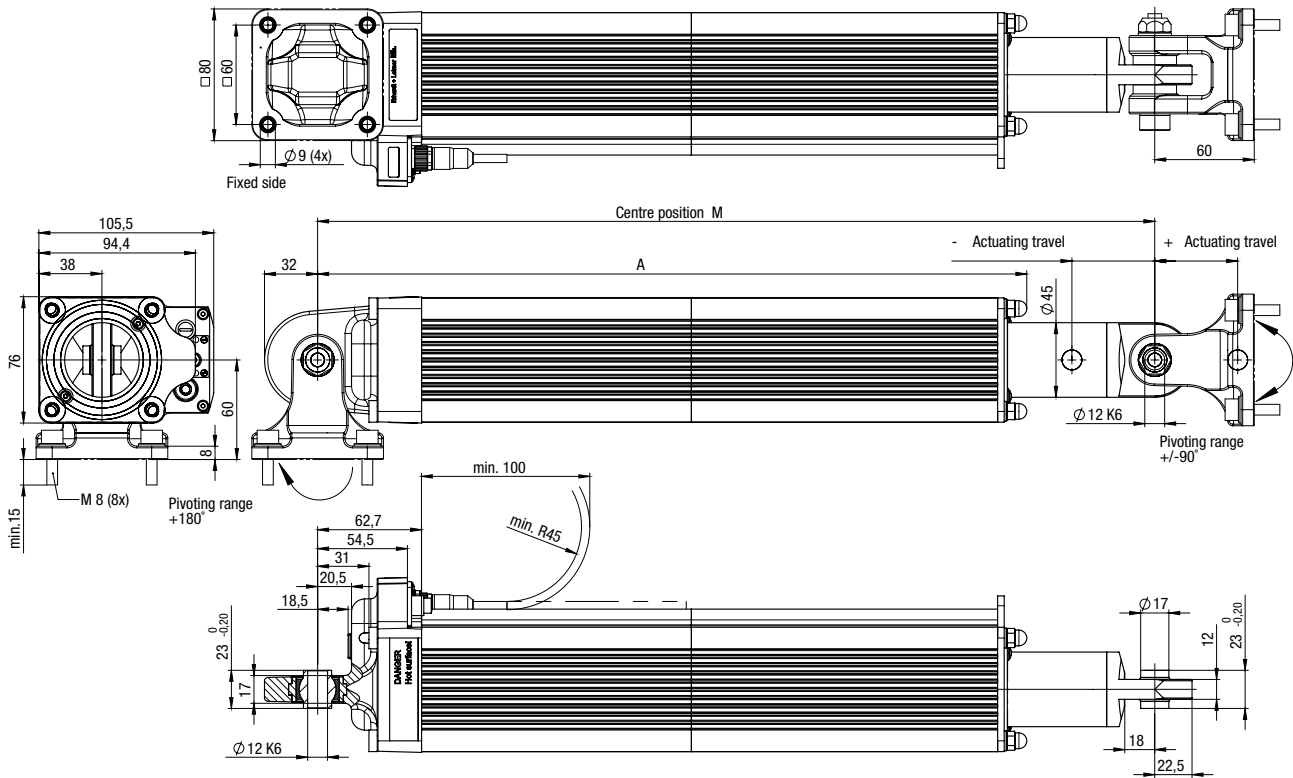

Linear drive units AG 96				
Type	Nominal actuating travel	Nominal actuating force	M	A
AG 9613	± 50 mm	5500 N	505 mm	428 mm
AG 9633	± 100 mm	5500 N	655 mm	528 mm
AG 9643	± 150 mm	5500 N	805 mm	628 mm
AG 9653	± 200 mm	5500 N	955 mm	728 mm

Formulas used for the drive calculations

	Translation	Rotation
Speed	$v = \frac{s}{t}$	$v = \omega \cdot r ; \omega = 2\pi \cdot \frac{n}{60}$
Distance	$s = v \cdot t$	$\rho = \omega \cdot t = 2\pi \cdot \frac{n}{60} \cdot t$
Acceleration	$a = \frac{v}{t_a}$	$\alpha = \frac{\omega}{t_a}$
Torque		$M = F \cdot r$
Power	$P = F \cdot v$	$P = M \cdot \omega = M \cdot 2\pi \cdot \frac{n}{60} \sim \frac{M \cdot n}{9.55}$
Force	$F = m \cdot a$	$F = J_R \cdot \alpha$
Work	$W = F \cdot s = \frac{m \cdot v^2}{2}$	$W = M \cdot \rho = \frac{J_a \cdot \omega^2}{2}$
Moment of inertia	$J_T = m_T \cdot r^2$	Cylinder: $J_R = m_R \cdot r^2$ Full cylinder: $J_R = \frac{1}{2} \cdot m_R \cdot r^2$ Hollow shaft: $J_R = \frac{1}{2} \cdot m_R \cdot (r_1^2 + r_2^2)$
Centrifugal force	$Z = \frac{m \cdot v^2}{r}$	$Z = m \cdot \omega^2 \cdot r$

Drive type	Speed
Spindle drive	$n_{Machine} = \frac{v \cdot 60}{h}$
Rack/lifting drive	$n_{Machine} = \frac{v \cdot 60}{\pi \cdot d_R}$

Drive type	Load torque
Spindle drive	$M_{Load} = h \cdot \frac{m_{LinMov} \cdot \mu g + F_f}{2 \cdot \eta}$
Rack drive	$M_{Load} = r \cdot m_{LinMov} \cdot \mu g + \frac{F_f}{\eta}$
Lifting drive	$M_{Load} = \frac{m_{LinMov} \cdot g r}{\eta}$

Drive type	Moment of inertia
Spindle drive	$J_T = m_{LinMov} \cdot \left(\frac{h}{2\pi}\right)^2$
Rack/lifting drive	$J_T = m_{LinMov} \cdot r^2$

Moment of inertia	
Total of the machine	$J_{Mach} = J_T + J_R$
In relation to gearbox	$J_{GearMot} = J_M \cdot i^2 + J_{Gearbox}$
Total on gear shaft	$J_{Tot} = J_{Mach} + J_{GearMot}$

Acceleration	
Total torque/time on gear shaft	$M_\alpha = \frac{n_2 \cdot J_{Tot}}{9.55 \cdot t_a} ; t_a = \frac{n_2 \cdot J_{Tot}}{9.55 \cdot M_\alpha}$

Symbol	Meaning	Unit
a	Acceleration	[m/s ²]
F	Force	[N]
F _f	Feed force	[N]
g	9.81	[m/s ²]
h	Spindle pitch	[m]
i	Gear reduction	
J _{GearMot}	Moment of inertia of geared motor	[kgm ²]
J _M	Moment of inertia of mass on load side	[kgm ²]
J _{Mach}	Total moment of inertia of machine	[kgm ²]
J _R	Rotational moment of inertia	[kgm ²]
J _T	Translational moment of inertia	[kgm ²]
M	Torque	[Nm]
M _{Load}	Load torque	[Nm]
m _{LinMov}	Mass of linearly moved parts	[kg]
m _R	Rotating mass	[kg]
M _α	Acceleration torque	[Nm]
n	Speed	[rpm]
n _{Machine}	Machine speed	[rpm]
P	Power	[W]
r	Radius	[m]
s	Distance	[m]
t	Time	[s]
t _a	Acceleration or braking time	[s]
v	Speed	[m/s]
W	Work	[Nm]
Z	Centrifugal force	[N]
α	Angular acceleration	[1/s ²]
η	Efficiency	
μ	Coefficient of friction	
ρ	Turning angle	
ω	Angular velocity	[1/s]
	$9.55 \sim \frac{60}{2\pi}$	

Questionnaire

General data			
Customer			
Street			
Zip code		City/town	
Country		Internet	
Contact person			
Phone		E-mail	
Project			

Technical data			
Type of machine			
Make			
Position on the machine			
Task			
Function	<input type="checkbox"/> Torque control	<input type="checkbox"/> Speed control	<input type="checkbox"/> Position control
Required torque	_____ Nm		
Required speed	_____ rpm		
Moment of inertia	_____ kg/m ²		
Ambient temperature	_____ °C		
Ambient conditions	<input type="checkbox"/> Dry	<input type="checkbox"/> Dusty	<input type="checkbox"/> Wet <input type="checkbox"/> _____
Operating voltage	<input type="checkbox"/> 24 V DC	<input type="checkbox"/> _____ V	<input type="checkbox"/> _____ Hz

Drive specification		
Flange plate	<input type="checkbox"/> With mounting flange	<input type="checkbox"/> Without mounting flange
End position limitation	<input type="checkbox"/> With end position limitation	<input type="checkbox"/> Without end position limitation
Functional safety	<input type="checkbox"/> With functional safety (STO)	<input type="checkbox"/> Without functional safety

Comments

Head office

Erhardt+Leimer GmbH
Albert-Leimer-Platz 1 · 86391 Stadtbergen, Germany
Tel.: +49 (0)821 2435-0
info@erhardt-leimer.com · www.erhardt-leimer.com



Subsidiaries

E+L Elektroanlagen Augsburg, Germany · E+L Automatisierungstechnik Augsburg, Germany
E+L Steuerungstechnik St. Egidien, Germany · E+L Bradford, United Kingdom · E+L Mulhouse, France
E+L Stezzano, Italy · E+L Bucharest, Romania · E+L Barcelona, Spain · E+L Burlington, Canada
E+L Duncan, S.C., USA · E+L Guarulhos-São Paulo, Brazil · E+L Ahmedabad, India · E+L Hangzhou, China
E+L Tao Yuan, Taiwan · E+L Yokohama, Japan · E+L Seoul, Republic of Korea · E+L Bangkok, Thailand



Subject to technical changes without notice · GRU-251815-EN-03 · 2/2024 · 853889