



ELSMART

Web guiding and spreading systems

Precise guiding and spreading of textile webs

Contents

Problems in the production process	4
Solutions from Erhardt+Leimer	5
Control loop	6
Position control methods	7
Infrared wide band sensor FE 45	8
Infrared edge sensor FR 52	9
Position controller RK 4004	10
Position controller RK 4310	11
Function of segmented roller guider ELSMART	12
Web guiding functions	13
Segmented roller guider system SWA95	14
Spreading device and rotary tensioner variant	15
Segmented roller guider system SWS95	16
Spreading device and rotary tensioner variant	17
Segmented roller guider system SWS94	18
Segmented roller guider system SWS94 with SW 9430 and center support	19
Segmented roller guider system SWS96	20
Segmented roller guider system SWS96 with spreading device LG 0673	21
Segmented roller guider system SWS97	22
Segmented roller guider system SWS97 with spreading device LG 05	23
Segmented roller guider system SWS91	24
All ELSMART products at glance	25
Web tension control ELTENS	26
Flange load cell PD 25	27
Flange load cell PD 23	28
Measuring amplifier CV 22	29
Web tension controller DC 62	30
Additional drives for segmented roller guider	31
Spreading device LG 067	32
Spreading device LG 052	33
Spreading roller BG	34
Pneumatic selvedge opener LP 03	35
Integrated web width measurement	36
"Stand alone" web width measurement	37
Function of steering roller system ELSWING	38
Steering roller system SRA83	39
Web guiding with web guider ELTWIN	40
Web guider KF 20	41
Support beam VWG for web guider	42
Questionnaire	43
Other products for the textile industry	47

FOCUS ON CUSTOMER SATISFACTION

INTELLIGENT TECHNOLOGY · SMART PRODUCTS

INTERNATIONAL LOCATIONS · WORLDWIDE AVAILABILITY

CUTTING-EDGE TECHNOLOGY AT HOME ALL OVER THE WORLD

Erhardt+Leimer

Global solutions for production of the future

Intelligent technologies and products in the highest quality designed to optimize the production processes of our customers all around the world. This is our claim as the internationally expanding Erhardt+Leimer group of companies.

With our global presence – from development to production and on to service – we are always close to the customer. We develop customer-specific solutions and provide our customers with excellent products either in digital or intelligent versions depending on their preference. Not only this, but we also set new standards for the production of tomorrow. In the process, it is not just our products that are increasingly becoming smart – our entire company is currently undergoing a digital transformation. One visible indication of this is the E+L online shop, which enables our customers to order products and spare parts quickly and easily from our website.

With more than 1,600 employees at sites across Europe, Asia, and America we deliver cutting-edge technology on-time to any location in the world.

In everything we do, we aim to use all company resources responsibly to protect the environment and demonstrate our commitment to increased sustainability.



Problems in the production process

Typical position errors

Web offset on batch change

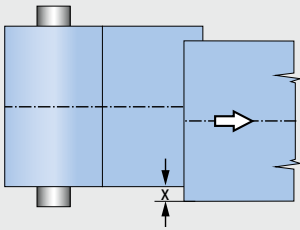

Lateral web movement from the plaiter carriage

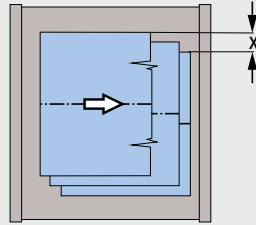

Lateral web movement in the process

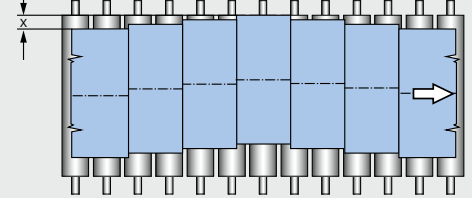

Typical creasing and width errors

Curled/folded-over edges

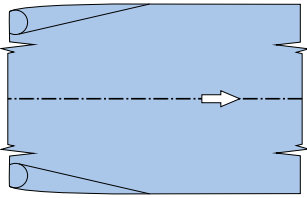

Diagonal creases

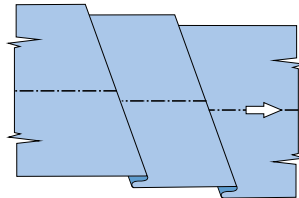

Typical web tension errors

Excessively low web tension at the unwinder

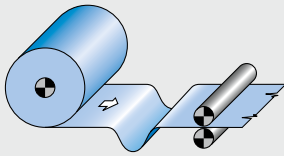

Excessively low web tension at the rewinder

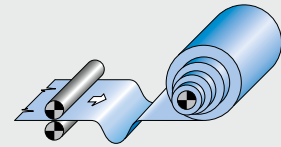

Excessively high web tension at the unwinder

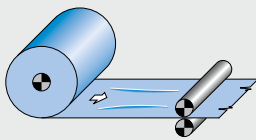

Excessively low or high web tension in the process

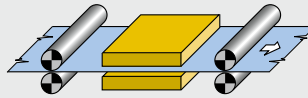

Excessively high web tension at the rewinder

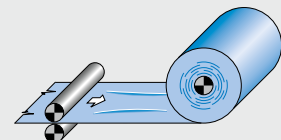

Typical width tolerance for web with lateral elasticity

Width tolerances (lateral elasticity)

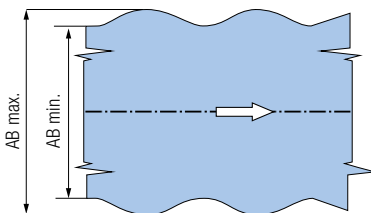

Typical width errors

Web too narrow

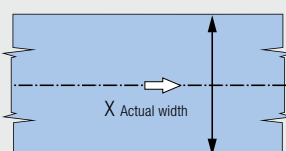

Web too wide

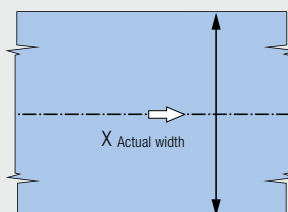

Solutions from Erhardt+Leimer

Web guiding

- Guiding by web edge or web center
- Correction of infeed and seam offset errors

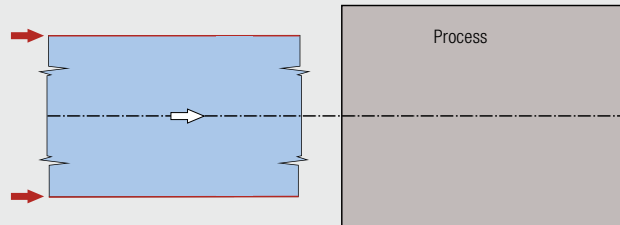

Web spreading

- Reliable uncurling of the web edges
- Spreading of creases and folded-over edges

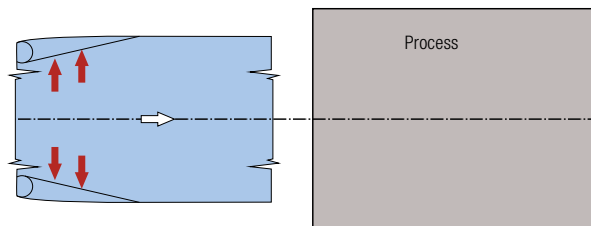

Web tension control

- Constant web tension through the entire process
- Reproducible production

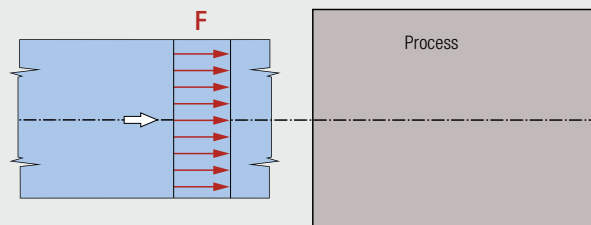

Web width control

- Defined target width for web with lateral elasticity

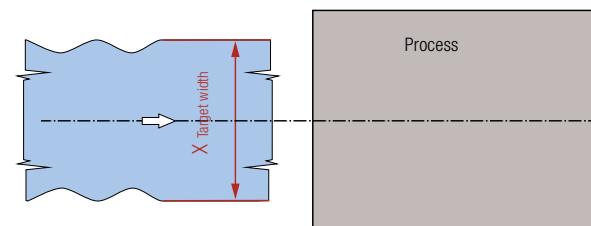

Web width monitoring

- Width measurement with width monitoring

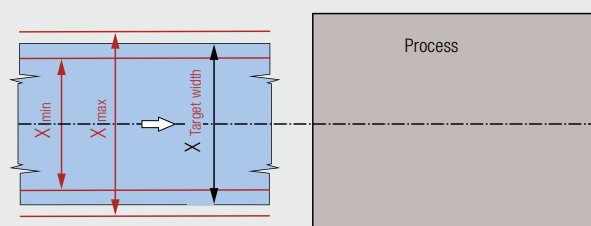

Control loop

1. The starting point is the actual web position.
2. A sensor acquires the actual position of the web without contact. Depending on the task, this sensor can be an edge sensor or a wide band sensor.
3. The controller compares the actual position of the web with the pre-defined target value and sends a corresponding correction signal to the actuator.
4. The actuator corrects the lateral position of the moving web.

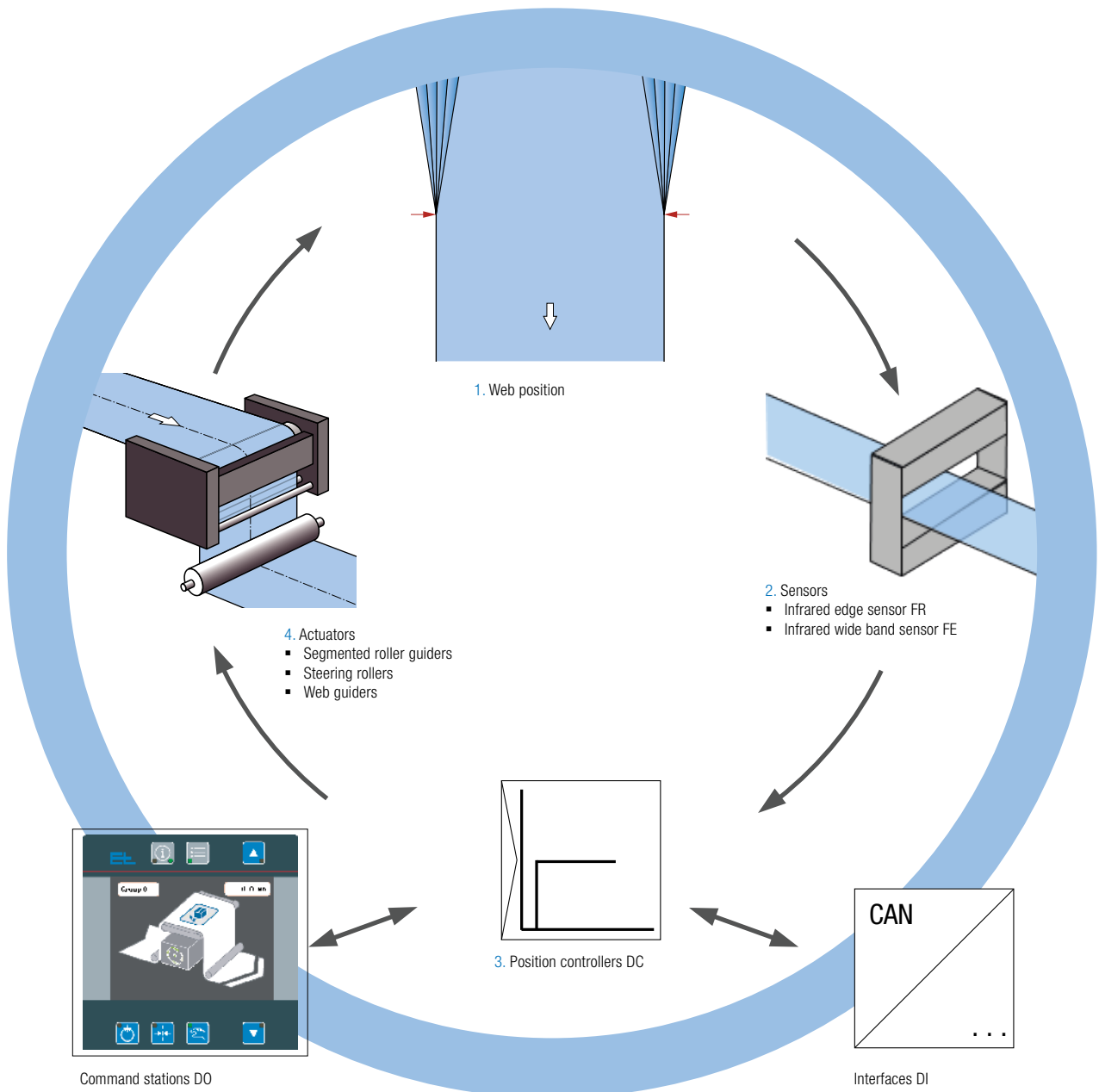

Position control methods

Web edge guiding

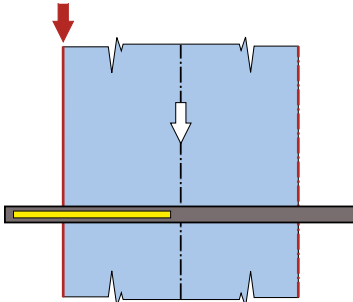

Edge acquisition using wide band sensor
Control by the right or left web edge

Web center guiding

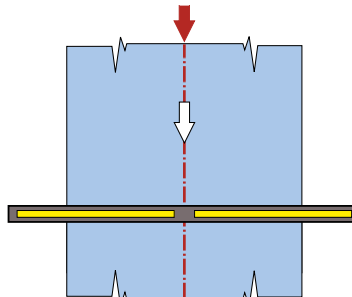

Guiding by the web center using wide band sensor

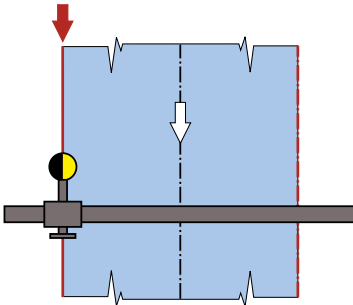

Edge acquisition using edge sensor
Control by the right or left web edge

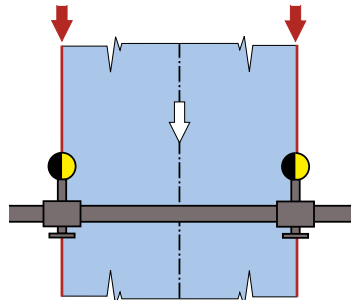

Guiding by the web center using two edge sensors

Web oscillation

Oscillation refers to controlled changes in the position of the web following a specific cycle. This cycle can be time-based or length-based.

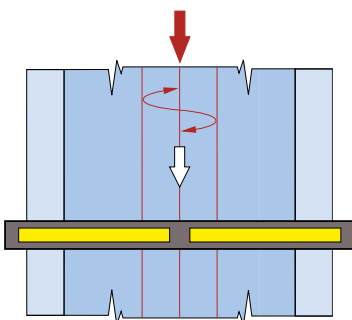

Web width measurement

If both web edges are acquired using a wide band sensor, the actual web width can also be calculated and displayed.

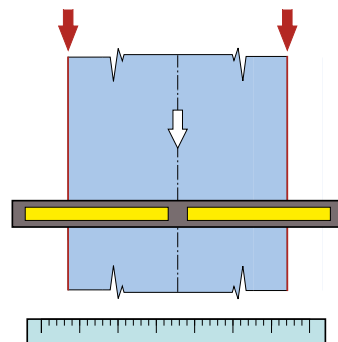

Infrared wide band sensor FE 45

- Digital wide band sensor for web center, web edge acquisition and width measurement up to a maximum operating width of 3800 mm (special widths up to 5000 mm)
- Reliable scanning principle with infrared light
- High immunity to transparency fluctuations and external light
- Protective tubes made of Plexiglas for dry and damp operation and made of glass for wet areas
- Special version for steam and chemical area



Infrared wide band sensor FE 45

Selection table

For dry and damp environment

Type	Resolution	Material
FE 4511	±5 mm	Plexiglas
FE 4521	±3 mm	Plexiglas
FE 4531	±1 mm	Plexiglas

For wet environment

Type	Resolution	Material
FE 4513	±5 mm	Glass
FE 4523	±3 mm	Glass
FE 4533	±1 mm	Glass

Flange version for steamer

Type	Resolution	Material
FE 4514	±5 mm	PTFE
FE 4524	±3 mm	PTFE
FE 4534	±1 mm	PTFE

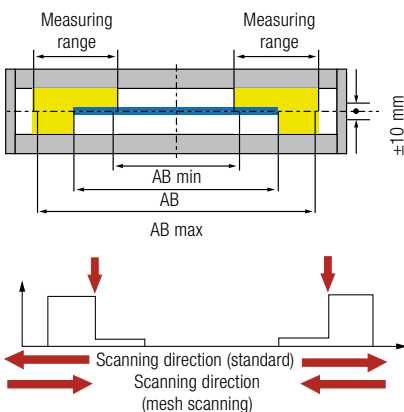

Technical data

Measuring range	Standard	Web edge	Web center
	High	Max. 1700 mm	Max. 3400 mm
	Premium	Max. 1700 mm	Max. 3400 mm
		Max. 900 mm	Max. 1800 mm
Operating width		Min. 400 mm	
		Max. 3800 mm	
		Special design up to 5000 mm	
Clear width	Plexiglas	80 mm	
	Glass	75 mm	
Resolution	Standard	±5 mm	
	High	±3 mm	
	Premium	±1 mm	
Width measurement accuracy	Standard	±10 mm	
	High	±6 mm	
	Premium	±2 mm	
Web position (height fluctuation)		Max. ±10 mm around the sensor center axis	
Operating voltage	Nominal value	24 V DC	
	Nominal range	20 V to 30 V DC (ripple included)	
Current consumption		200 mA	
Wavelength		850 nm	
Scan rate		200 Hz	
Length of sensor cable		25 m	
Interface		Sensor CAN, protocol 2.0/M16	
Ambient temperature		+10 °C to +60 °C	
		+10 °C to +100 °C (FE 4514/24/34)	
Storage temperature		+0 °C to 85 °C	
Atmospheric humidity		15 % to 95 % (non-condensing)	
Protection class		IP 54	
Weight Premium		Approx. 15 kg (AB 1600 mm)	
		Approx. 30 kg (AB 3200 mm)	

Infrared edge sensor FR 52

- Infrared edge sensor based on the principle of retroreflection
- Measuring range ± 10 mm with a resolution of 0.02 mm
- Distance-independent edge evaluation based on parallel light beams
- Acquisition of edges and threads
- Scanning with CCD array guarantees a stable operating point independent of the material transparency
- Exposure controller for the compensation of soiling
- Optional integrated air purge system for extreme dust conditions
- Bar display for the indication of the current edge position or diagnostic information



Infrared edge sensor FR 52



FR 52 with reflector bar



Infrared edge sensor FR 52 for mesh fabric acquisition

Selection table

Reflector bar

Type	Fork width
FR_5000-95	30 mm
FR_5000-97	75 mm
FR_5000-98	160 mm

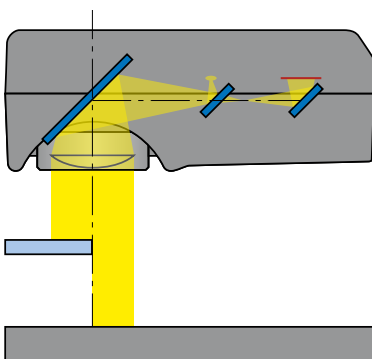

Principle of operation FR 52

Technical data

Measuring range	± 10 mm
Resolution	0.02 mm
Linearity	± 0.1 mm
Operating voltage	
Nominal value	24 V DC
Nominal range (ripple included)	20 to 30 V DC
Current consumption	80 mA DC
Wavelength	850 nm
Scan rate	200 Hz
Cable length	Max. 10 m
Interface	Sensor CAN, protocol 2.0/M16
Dimensions (L x W x H)	105 x 50 x 40 mm
Ambient temperature	+10 °C to +50 °C
Atmospheric humidity	15 % to 95 % (non-condensing)
Protection class	IP 54
Weight	0.3 kg
Air purge system operating pressure	Min. 0.1 bar; max. 0.2 bar
Service unit filter	5 μ m
Service unit residual oil content	< 0.01 mg/m ³

Position controller RK 4004

- Digital position controller with integrated output stage for the operation of DC geared motors
- Cascaded control structure for the precise control of integral actuators
- Stable speed control loop due to incremental acquisition of the speed and calculation of the actual speed
- Integrated CAN bus for network of E+L control systems
- Backup solution for saving the parameters and device settings

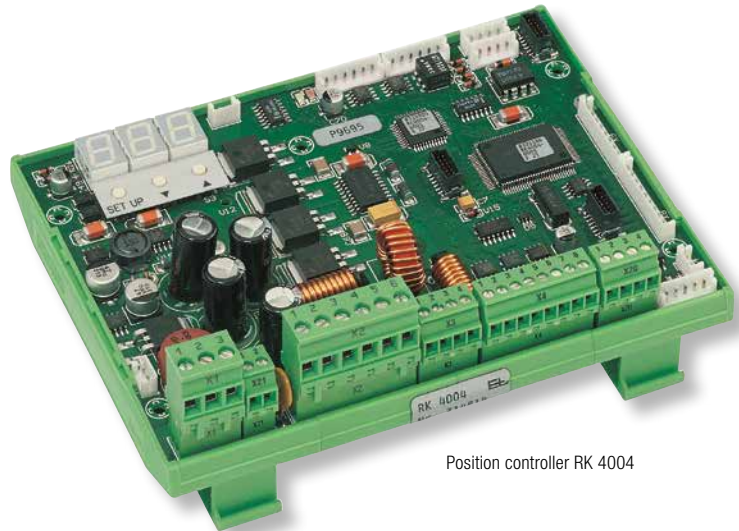

Position controller RK 4004

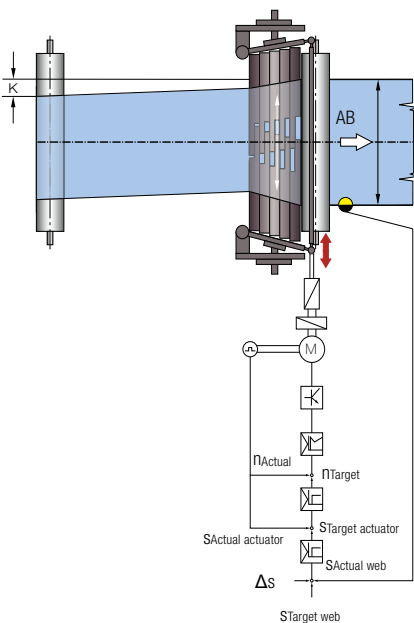

Legend

K	Infeed error
AB	Operating width
SActual actuator	Actual position, actuator
STarget actuator	Target position, actuator
SActual web	Actual position, web
STarget web	Target position, web
Δs	Web offset

Technical data

Operating voltage	
Nominal value	24 V DC
Nominal range	20 V to 30 V DC
Current consumption	
Without motor	0.2 A DC
With motor	5.2 A DC
Output voltage	
At motor terminal	± 22 V (pulse width modulated)
Output current	Max. 5 A
Cycle time	6 ms
Ambient temperature	+10 °C to +50 °C
Relative atmospheric humidity	15 % to 95 % (non-condensing)
Protection class	
Without housing	IP 00
With housing	IP 54
Fieldbus	CAN bus / 250 kbit/s
Digital inputs	5x configurable Low = 0 V to 3 V DC High = 10 V to 30 V DC
Digital output	1x configurable PNP, max 0.1 A

Position controller RK 4310

- Digital position controller for the operation of pneumatic valves
- Control structure with three-point controller for integral actuator
- Integrated CAN bus for network of E+L control systems
- With USB connection for service tool ELBUDDY
- Backup solution for saving the parameters and device settings

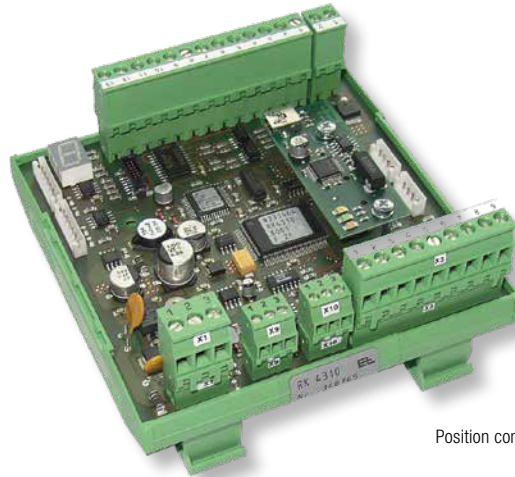

Position controller RK 4310

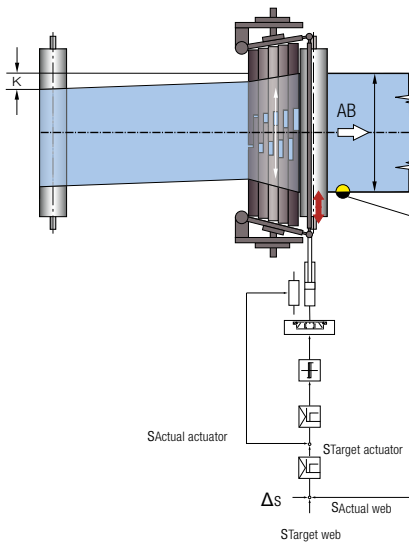

Legend

- | | |
|------------------|---------------------------|
| K | Infeed error |
| AB | Operating width |
| SActual actuator | Actual position, actuator |
| STarget actuator | Target position, actuator |
| SActual web | Actual position, web |
| STarget web | Target position, web |
| Δs | Web offset |

Technical data

Operating voltage	
Nominal value	24 V DC
Nominal range	20 to 30 V DC
Current consumption	0.2 A DC
Cycle time	6 ms
Ambient temperature	+10 °C to +50 °C
Relative atmospheric humidity	15 % to 95 % (non-condensing)
Protection class	
Without housing	IP 00
With housing	IP 54
Fieldbus	CAN bus / 250 kbit/s
Digital inputs	1x inversion of scanning direction, floating 1x configurable, floating "0" signal = 0 V to 3 V DC "1" signal = 10 V to 30 V DC
Digital output	2x configurable, floating and short circuit proof "High" signal = supply voltage Output current 1 A (briefly 1.9 A)

Function of segmented roller guider ELSMART

Function

Guiding slats arranged around the circumference form the basis of the web guiding. In the basic version, the guiding slats are fixed to a guide plate so that they can be adjusted to the side via an actuating drive. In the case of segmented guiding slats, both guide plates are connected with a push rod and adjusted synchronously via an actuating drive. In this way web guiding with superimposed web spreading is realized.

If two actuating drives are used, a laterally elastic web can be regulated based on a defined target width or adjustable spreading. Alternatively, two webs can also be guided independently of each other by edge or web center.

Area of use

Due to the minimum stress applied to the material by the segmented roller guider, the ELSMART system for web guiding and spreading can be used in almost all textile production processes. It is a prerequisite here that the textile web does not display high surface stability.

Application

Segmented roller guiders can be used freely in terms of position.

Wrapping of 90° is always required. Entry point 90°, exit point 180°. The infeed path should be at least one web width. By contrast, the exit should be kept as short as possible. Curled edges can be uncurled in the infeed plane with the aid of an additional spreading device.

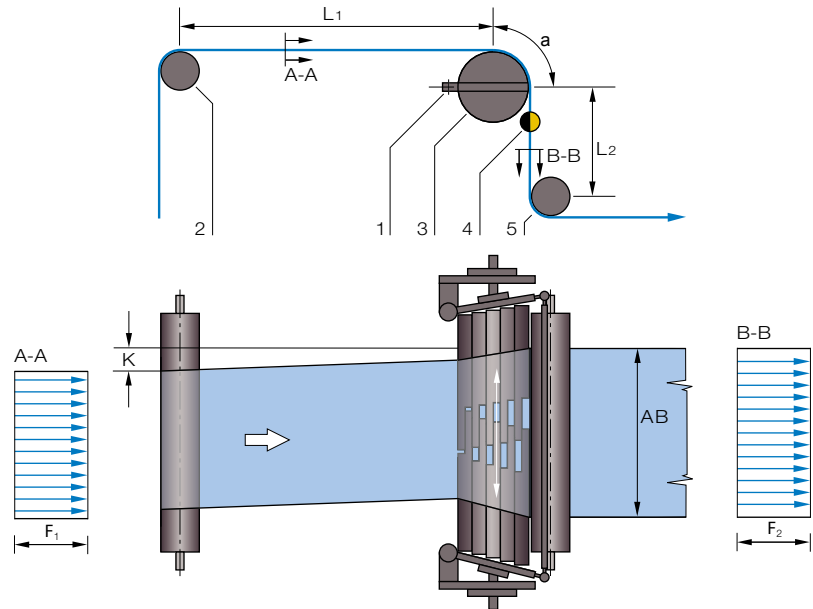

Legend

A-A	Web tension distribution at the infeed	1	Swiveling axis
B-B	Web tension distribution at the exit	2	Infeed roller/rod
K	Web correction	3	Segmented roller guider
α	Wrap angle 90°	4	Sensor
F ₁	Basic web tension at the infeed	5	Locking roller
F ₂	Basic web tension at the exit	L ₁	Infeed path
AB	Operating width	L ₂	Exit path

Selection of facings

Type	Mohair Standard facing with good surface structure for dry/damp webs	PVC For dry and wet webs	Stainless steel For wet (chemically laden) webs	Stainless steel with nubs For wet (chemically laden) and dry webs	Perforated stainless steel For wet and chemically laden webs in steamers and washing machines
SWS91	■	■			
SWS94	■	■			
SWS95	■	■			
SWA95	■	■			
SWS96		■	■	■	
SWS97					■



Web guiding functions

Web guiding

- Version with continuous guiding slats over the entire width of the web
- Cost-effective solution for pure web guiding

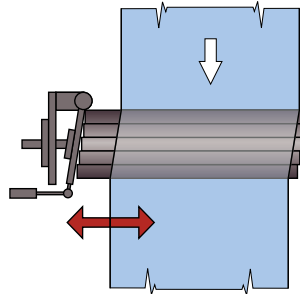

Web guiding with spreading

- Version with segmented guiding slats
- Additional spreading along with web guiding
- Spreading mechanically adjustable

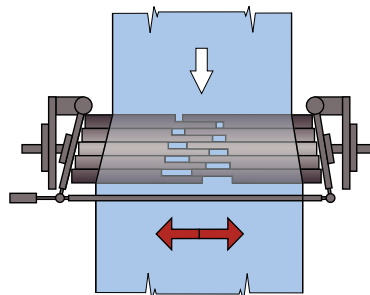

Web width control

- Version with segmented guiding slats and two separate control loops
- Width control for laterally elastic fabric webs
- Spreading electrically adjustable

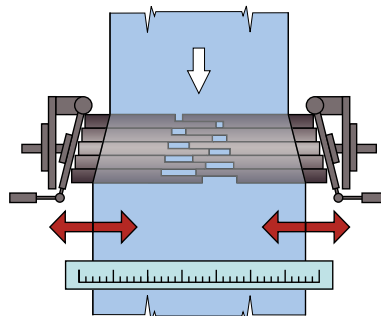

Guiding two webs

- Version with segmented guiding slats and two separate control loops
- Parallel web guiding for two fabric webs by web edge and web center
- Spreading not possible

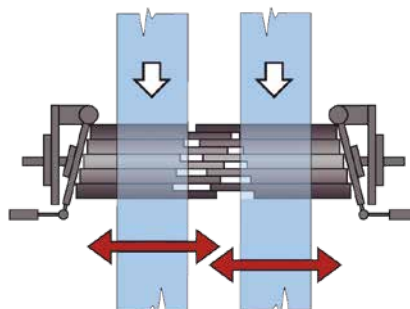

Segmented roller guider system SWA95

- Precise guiding of woven and knitted fabrics in dry and damp operation
- Integrated edge acquisition with wide band sensor or infrared edge sensor
- Gentle and reliable control of the textile web using pneumatic actuating drive on the segmented roller guider up to a machine speed of 130 m/min
- Continuous guiding slats for web guiding, segmented guiding slats for web guiding with superimposed spreading
- Optionally with web tension-controlled additional drive for constant web tension in the downstream process



Segmented roller guider SWA95



Segmented roller guide system SWA9501 on the exit from a tumbler

Technical data

Positional accuracy	±10 mm (wide band sensor FE 45, standard resolution)
Correction range	±300 mm (depending on web width, infeed path and web type)
Spreading	0 mm to 12 mm (works setting 9 mm)
Web speed	Max. 130 m/min
Web tension	Max. 1000 N
Operating width	1600 mm to 3600 mm (roller diameter 215 mm)
Operating voltage	24 V DC
Ambient temperature	0 °C to +60 °C
Ambient conditions	Dry and damp
Protection class	IP 54

Selection table, segmented roller guiders SWA95 with pneumatic adjustment

System	Actuator	Area of application	Mounting	Drive	Guiding slat	Sensor	Type of control	Spreading	Rotary tensioner
SWA9501	SW 9562	Dry, damp	Box	1x pneum. drive	Continuous	FE 45	Web center	without	without
SWA9551	SW 9570	Dry, damp	Box	1x pneum. drive	Segmented with push rod	FE 45	Web center	without	without
SWA9511	SW 9562	Dry, damp	Box	1x pneum. drive	Continuous	FE 45	Web center	LG 0671	without
SWA9561	SW 9570	Dry, damp	Box	1x pneum. drive	Segmented with push rod	FE 45	Web center	LG 0671	without
SWA9511	SW 9562	Dry, damp	Box	1x pneum. drive	Continuous	FE 45	Web center	LG 0671	DS 11
SWA9561	SW 9570	Dry, damp	Box	1x pneum. drive	Segmented with push rod	FE 45	Web center	LG 0671	DS 11

Spreading device and rotary tensioner variant

Segmented roller guider system SWA95 combined with spreading system LG 0671

- Along with the web guiding, this combination ensures reliable spreading of folded webs and curled edges
- Complete spreading, even of webs with a high Lycra content or knitted fabrics with manifold curled edges

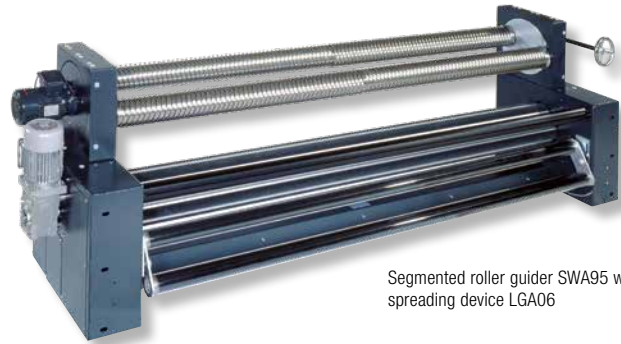

Segmented roller guider SWA95 with spreading device LGA06



Segmented roller guider system SWA9511 after the J-box before a tenter

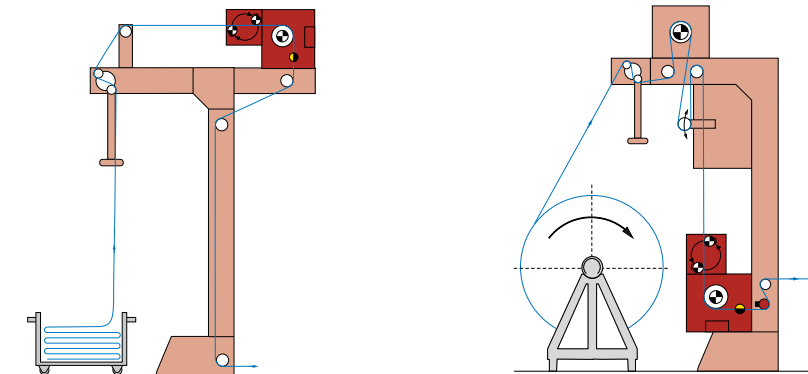

Segmented roller guider SWA95 combined with spreading system LG 0671 and rotary tensioner DS 11

- Along with web guiding and spreading, the combination with an additional rotary tensioner ensures optimal, cost-effective machine infeed
- Simple mounting of the complete system on the machine line by fastening the segmented roller guider

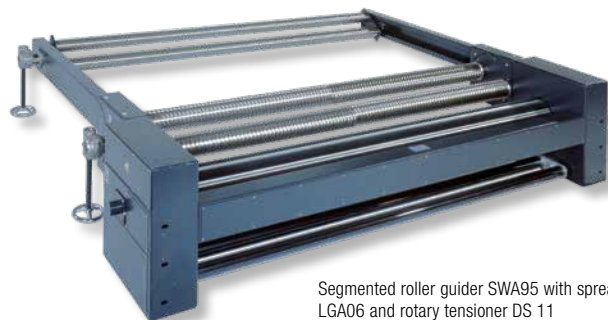

Segmented roller guider SWA95 with spreading device LGA06 and rotary tensioner DS 11



Segmented roller guider system SWA9511 on rotary printing machine infeed

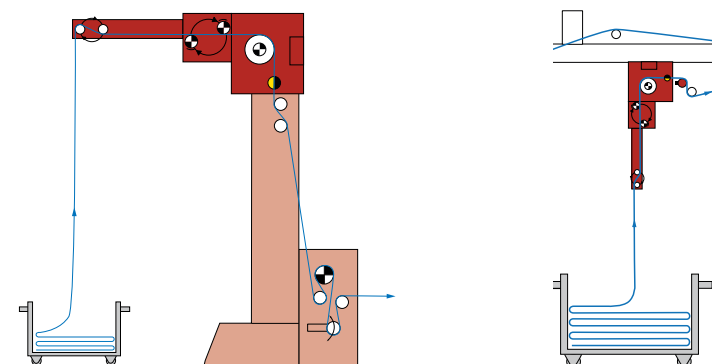

Segmented roller guider system SWS95

- Precise guiding of woven and knitted fabrics in dry and damp operation
- Integrated edge acquisition with wide band sensor or infrared edge sensor
- Gentle and reliable control of the textile web using electrical actuating drive on the segmented roller guider up to a machine speed of 220 m/min
- Continuous guiding slats for web guiding, segmented guiding slats for web guiding with superimposed spreading
- Optionally with web tension-controlled additional drive for constant web tension in the downstream process

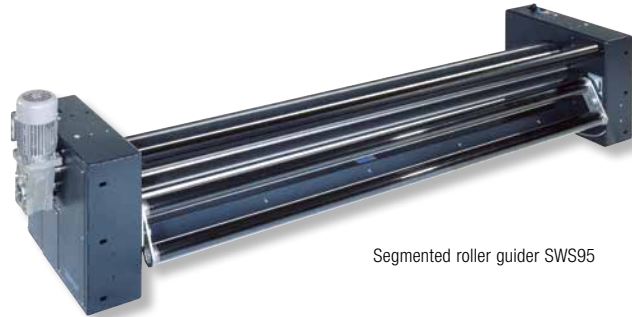

Segmented roller guider SWS95

Technical data

Positional accuracy	±1 mm (infrared edge sensor FR 52) ±5 mm (wide band sensor FE 45, standard resolution)
Correction range	±300 mm (depending on web width, infeed path and web type)
Spreading	0 mm to 12 mm (works setting 9 mm)
Web speed	Max. 220 m/min
Web tension	Max. 1000 N
Operating width	1600 mm to 3600 mm (roller diameter 215 mm)
Operating voltage	24 V DC
Ambient temperature	+0 °C to +60 °C
Ambient conditions	Dry and damp
Protection class	IP 54

Selection table, segmented roller guiders SWS95 with electrical drive

System	Actuator	Area of application	Mounting	Drive	Guiding slat	Sensor	Type of control	Spreading	Rotary tensioner
SWS9501	SW 9562	Dry, damp	Box	1x elec.	Continuous	FE 45	Web center	without	without
SWS9503	SW 9562	Dry, damp	Box	1x elec.	Continuous	FR 52	Web edge	without	without
SWS9551	SW 9570	Dry, damp	Box	1x elec.	Segmented with push rod	FE 45	Web center	without	without
SWS9553	SW 9570	Dry, damp	Box	1x elec.	Segmented with push rod	FR 52	Web edge	without	without
SWS9554	SW 9570	Dry, damp	Box	1x elec.	Segmented with push rod	2x FR 52	Web center	without	without
SWS9594	SW 9580	Dry, damp	Box	2x elec.	Segmented	2x FR 52	Web width Web center	without	without
SWS9584	SW 9580	Dry, damp	Box	2x elec.	Segmented	2x FR 52	Web width Web center	LP 03	without
SWS9511	SW 9562	Dry, damp	Box	1x elec.	Continuous	FE 45	Web center	LG 0671	without
SWS9561	SW 9570	Dry, damp	Box	1x elec.	Segmented with push rod	FE 45	Web center	LG 0671	without
SWS9511	SW 9562	Dry, damp	Box	1x elec.	Continuous	FE 45	Web center	LG 0671	DS 11
SWS9561	SW 9570	Dry, damp	Box	1x elec.	Segmented with push rod	FE 45	Web center	LG 0671	DS 11

Spreading device and rotary tensioner variant

Segmented roller guider system SWS95 combined with spreading system LG 0671

- Along with the web guiding, this combination ensures reliable spreading of folded webs and curled edges
- Complete spreading, even of webs with a high Lycra content or knitted fabrics with manifold curled edges



Segmented roller guider SWS95 with spreading device LGA06

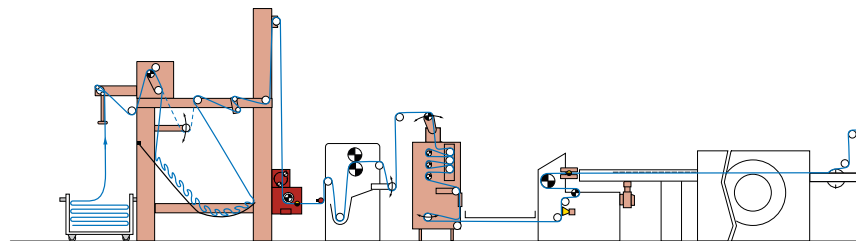

Segmented roller guider system SWS95 on tenter infeed

Segmented roller guider system SWS95 combined with pneumatic selvage opener LP 03

- Along with web guiding, the pneumatic selvage openers ensure optimally uncurled web edges immediately in front of the printing blanket
- Simple mounting of the complete system on the machine line by fastening the segmented roller guider

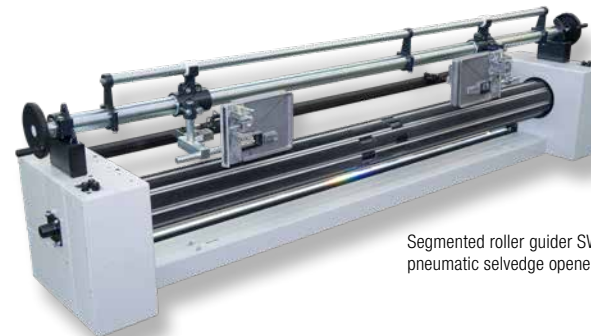

Segmented roller guider SWS95 with pneumatic selvage opener LP 03



Segmented roller guider system SWS95 on rotary printing machine infeed

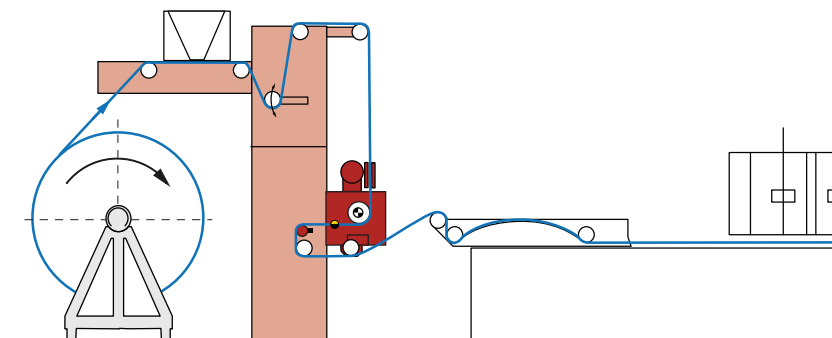

Segmented roller guider system SWS95 on digital printing machine infeed

Segmented roller guider system SWS94

- Precise guiding of woven and knitted fabrics in dry and damp operation
- Compact, lightweight version with adjustable mounting bracket for adaptation to existing direction of web travel
- Integrated edge acquisition with wide band sensor or infrared edge sensor
- Gentle and reliable control of the textile web using electrical actuating drive on the segmented roller guider up to a machine speed of 200 m/min
- Continuous guiding slats for web guiding, segmented guiding slats for web guiding with superimposed spreading
- Optionally with web tension-controlled additional drive for constant web tension in the downstream process



Segmented roller guider system SWS94 on rotary printing machine infeed

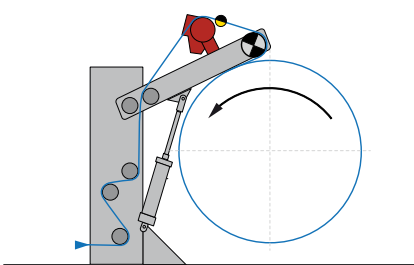

Segmented roller guider system SWS94 on Sochor arm in front of rewinder



Segmented roller guider SWS94

Technical data

Positional accuracy	±1 mm (infrared edge sensor FR 52), ±5 mm (wide band sensor FE 45, standard resolution)
Correction range	±300 mm (depending on web width, infeed path and web type)
Spreading	0 mm to 12 mm (works setting 9 mm)
Web speed	Max. 200 m/min
Web tension	Max. 1000 N
Operating width	1600 to 3600 mm (roller diameter 215 mm)
Operating voltage	24 V DC
Ambient temperature	+0 °C to +60 °C
Ambient conditions	Dry and damp
Protection class	IP 54

Selection table, segmented roller guider SWS94 with electrical drive

System	Actuator	Area of application	Mounting	Drive	Guiding slat	Sensor	Type of control	Spreading
SWS9401	SW 9462	Dry, damp	Base	1x drive	Continuous	FE 45	Web center	without
SWS9403	SW 9462	Dry, damp	Base	1x drive	Continuous	FR 52	Web edge	without
SWS9451	SW 9470	Dry, damp	Base	1x drive	Segmented with push rod	FE 45	Web center	without
SWS9453	SW 9470	Dry, damp	Base	1x drive	Segmented with push rod	FR 52	Web edge	without
SWS9473	SW 9470	Dry, damp	Base	1x drive	Segmented with push rod	FR 52	Web edge	LP 03
SWS9484	SW 9480	Dry, damp	Base	2x drive	Segmented	2xFR 52	Web width, web center	LP 03
SWS9494	SW 9480	Dry, damp	Base	2x drive	Segmented	2xFR 52	Web width, web center	without

Segmented roller guider system SWS94 with SW 9430 and center support

- Precise web guide of woven and knitted fabrics as well as carpet in dry and damp operation
- Compact version with mounting bracket and center support for operating widths from 3700 to 6000 mm
- Integrated edge acquisition with wide band sensor or infrared edge sensor
- Gentle and reliable control of the textile web using electrical actuating drive on the segmented roller guider up to a machine speed of 200 m/min
- Segmented guiding slats for web guiding with superimposed spreading
- Optionally with web tension-controlled additional drive for constant web tension in the downstream process

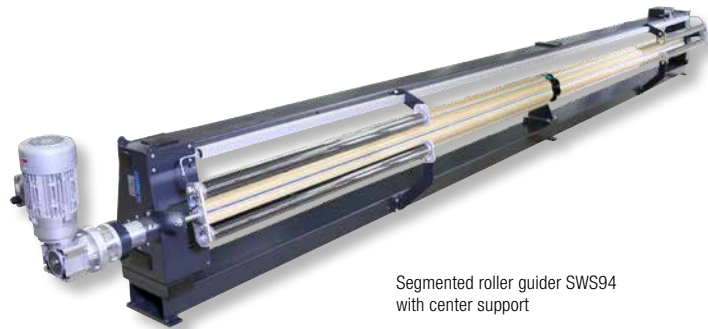

Segmented roller guider SWS94 with center support

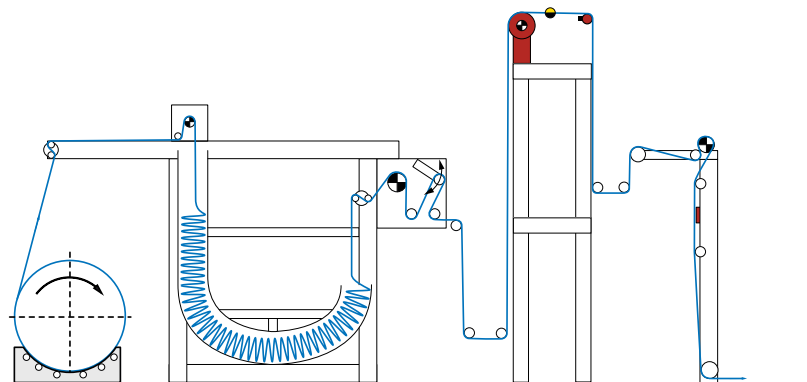

Segmented roller guider system SWS94 on carpet coating system infeed

Technical data

Positional accuracy	±5 mm (wide band sensor FE 45, standard resolution)
Correction range	±300 mm (depending on web width, infeed path and web type)
Spreading	0 mm to 12 mm (works setting 9 mm)
Web speed	Max. 200 m/min
Web tension	Max. 1000 N
Operating width	3700 mm to 6000 mm (roller diameter 215 mm)
Operating voltage	24 V DC
Ambient temperature	+0 °C to +60 °C
Ambient conditions	Dry and damp
Protection class	IP 54

Selection table

System	Actuator	Area of application	Mounting	Drive	Guiding slat	Sensor	Type of control	Spreading
SWS9451	SW 9430	Dry, damp	Base+center	1x drive	Segmented with push rod	FE 47	Web center	without

Segmented roller guider system SWS96

- Precise web guiding in stainless steel design for woven and knitted fabrics in wet and damp operation
- Integrated edge acquisition with wide band sensor
- Gentle and reliable control of the textile web using electrical actuating drive on the segmented roller guider up to a machine speed of 100 m/min
- Continuous guiding slats for web guiding, segmented guiding slats for web guiding with superimposed spreading
- Optionally with web tension-controlled additional drive for constant web tension in the downstream process

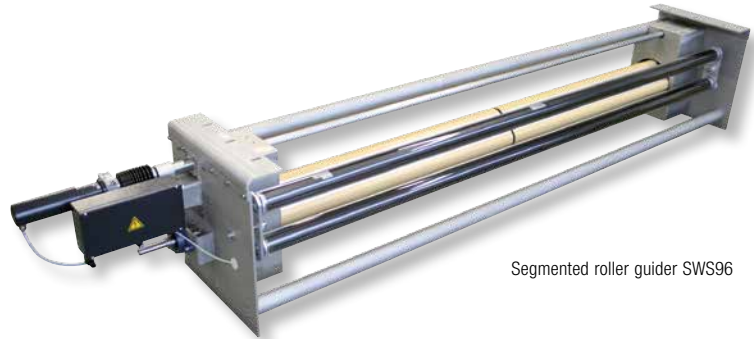

Segmented roller guider SWS96



Segmented roller guider system SWS96 on rope detwisting system

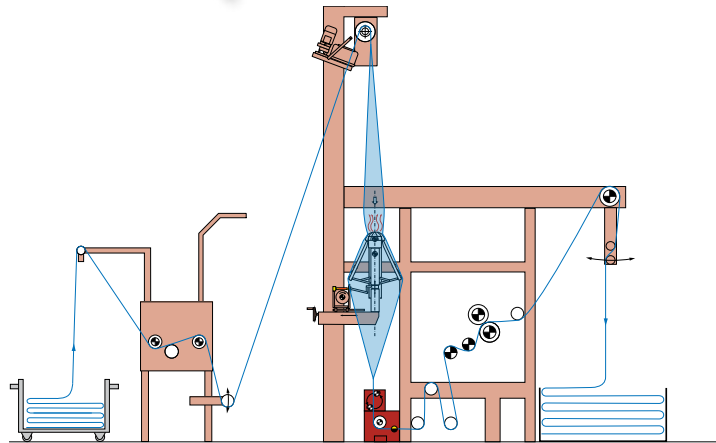

Segmented roller guider system SWS96 on rope detwisting system

Technical data

Positional accuracy	±5 mm (wide band sensor FE 45, standard resolution)
Correction range	±300 mm (depending on web width, infeed path and web type)
Spreading	0 mm to 12 mm (works setting 9 mm)
Web speed	Max. 100 m/min
Web tension	Max. 1000 N
Operating width	1600 mm to 3600 mm (roller diameter 215 mm)
Operating voltage	24 V DC
Ambient temperature	+0 °C to +60 °C
Ambient conditions	Damp and wet
Protection class	IP 65 (actuating drive IP 54)

Selection table

System	Actuator	Area of application	Mounting	Drive	Guiding slat	Sensor	Type of control	Spreading
SWS9601	SW 9662	Damp, wet	Box	1x elec. drive	Continuous	FE 45	Web center	without
SWS9651	SW 9670	Damp, wet	Box	1x elec. drive	Segmented with push rod	FE 45	Web center	without

Segmented roller guider system SWS96 with spreading device LG 0673

- Along with the web guiding, this combination ensures reliable spreading of folded webs and curled edges
- Complete spreading, even of webs with a high Lycra content or knitted fabrics with manifold curled edges

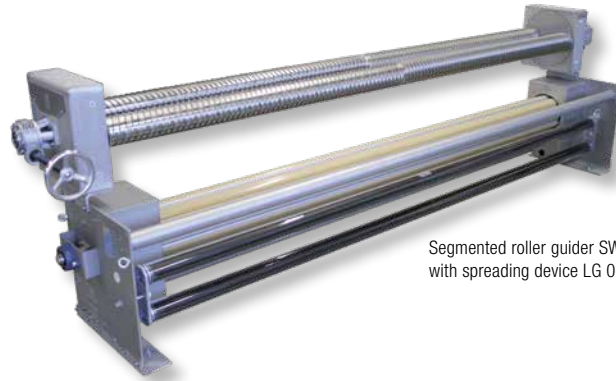

Segmented roller guider SWS96 with spreading device LG 0673



Segmented roller guider system SWS9611 in front of padder

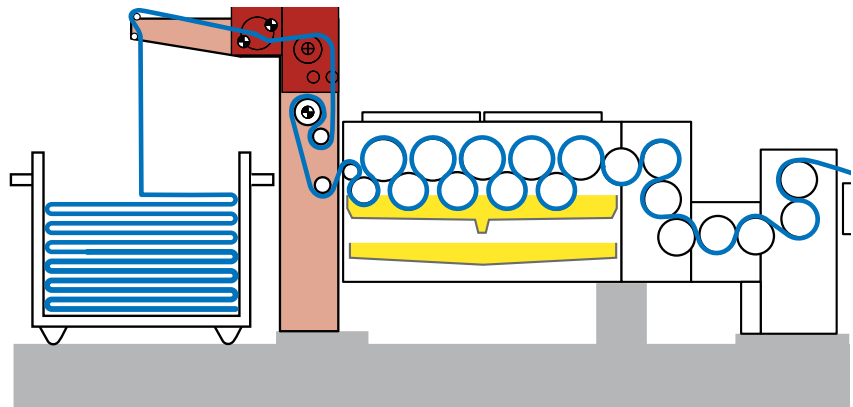

Segmented roller guider system SWS9611 in front of mercerizing machine

Technical data, spreading device

Operating width	1000 mm to 3600 mm (steps of 100 mm)
Diameter, spreading rollers	86 mm (AB 1000 mm to 2400 mm) 112 mm (AB 2500 mm to 3600 mm)
Speed, spreading rollers	268 1/min (50 Hz) 322 1/min (60 Hz)
Power consumption	0.55 kW (50 Hz) 0.63 kW (60 Hz)
Operating voltage	220 V - 240 V / 380 V - 420 V (50 Hz) 254 V - 280 V / 440 V - 480 V (60 Hz)
Ambient temperature	+10 °C to +60 °C
Ambient conditions	Damp and wet
Protection class	IP 54

Selection table

System	Actuator	Area of application	Mounting	Drive	Guiding slat	Sensor	Type of control	Spreading
SWS9611	SW 9662	Damp, wet	Box	1x elec. drive	Continuous	FE 45	Web center	LG 0673
SWS9661	SW 9670	Damp, wet	Box	1x elec. drive	Segmented with push rod	FE 45	Web center	LG 0673

Segmented roller guider system SWS97

- Precise web guiding in stainless steel design for woven and knitted fabrics in steam and wet operation to 100 °C
- Integrated edge acquisition with wide band sensor up to 100 °C
- Gentle and reliable control of the textile web using electrical actuating drive on the segmented roller guider up to a machine speed of 100 m/min
- Continuous guiding slats for web guiding, segmented guiding slats for web guiding with superimposed spreading
- Optionally with web tension-controlled additional drive for constant web tension in the downstream process



Segmented roller guider SWS97

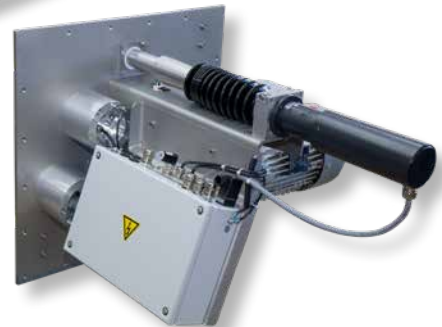

Segmented roller guider SWS97 drive side



Segmented roller guider system SWS97 in bleaching steamer

Technical data

Positional accuracy	±5 mm (wide band sensor FE 45, standard resolution)
Correction range	±300 mm (depending on web width, infeed path and web type)
Spreading	0 mm to 12 mm (works setting 9 mm)
Web speed	Max. 100 m/min
Web tension	Max. 1000 N
Operating width	1600 mm to 3600 mm (roller diameter 215 mm)
Operating voltage	24 V DC
Ambient temperature	+0 °C to +100 °C
Ambient conditions	Damp, wet and saturated steam
Protection class inside the machine	IP 65
Protection class outside the machine	IP 54

Selection table

System	Actuator	Area of application	Mounting	Drive	Guiding slat	Sensor	Type of control	Spreading
SWS9701	SW 9762	Damp, wet	Flange	1x elec. drive	Continuous	FE 45	Web center	without
SWS9751	SW 9770	Damp, wet	Flange	1x elec. drive	Segmented with push rod	FE 45	Web center	without

Segmented roller guider system SWS97 with spreading device LG 05

Segmented roller guider system SWS97 combined with spreading system LG 05

- Along with the web guiding, this combination ensures reliable spreading of folded webs and curled edges
- Complete spreading, even of webs with a high Lycra content or knitted fabrics with manifold curled edges



Segmented roller guider system SWS97 and LG05 in bleaching steamer

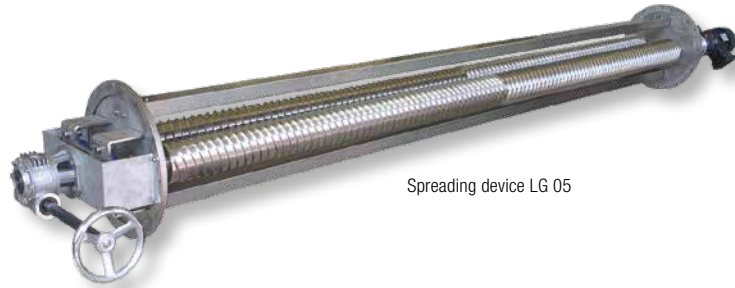

Spreading device LG 05

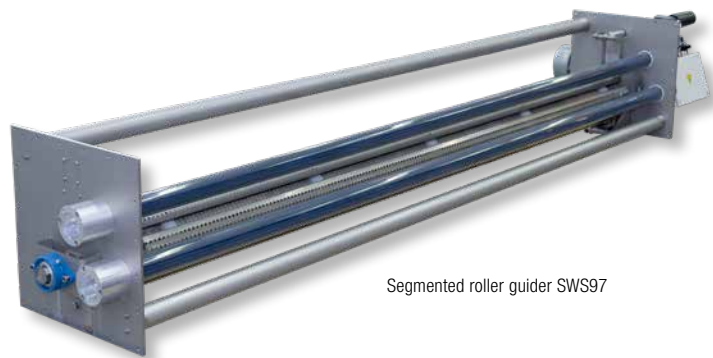

Segmented roller guider SWS97

Technical data

Operating width	1600 mm to 3600 mm (steps of 100 mm)
Diameter, spreading rollers	112 mm (AB 1600 mm to 3600 mm)
Framework width GA (outside)	AB +406 mm
Web tension	Max. 1000 N
Ambient temperature	+10 °C to +60 °C
Ambient conditions	Damp, wet, saturated steam
Speed, spreading rollers	245 1/min (50 Hz) 295 1/min (60 Hz)
Power consumption	0.55 kW
Operating voltage	220 V - 240 V / 280 V - 420 V (50 Hz) 254 V - 277 V / 440 V - 480 V (60 Hz)
Protection class	IP 55
Material	Stainless steel

Selection table

System	Actuator	Area of application	Mounting	Drive	Guiding slat	Sensor	Type of control	Spreading
SWS9711	SW 9762	Damp, wet	Box	1x elec. drive	Continuous	FE 45	Web center	LG 052
SWS9761	SW 9770	Damp, wet	Box	1x elec. drive	Segmented with push rod	FE 45	Web center	LG 052

Segmented roller guider system SWS91

- Precise guiding of woven and knitted fabrics in dry and damp operation or rubberized webs from the loop
- Integrated edge acquisition with wide band sensor or infrared edge sensor
- Gentle and safe control of the textile web using the electrical actuating drive of the segmented roller guider up to a machine speed of 50 m/min
- Continuous guiding slats for web guiding, segmented guiding slats for web guiding with superimposed spreading
- Optionally with web tension-controlled additional drive for constant web tension in the downstream process



Segmented roller guider SWS91

Technical data

Positional accuracy	±1 mm (infrared edge sensor FR 52) ±3 mm (wide band sensor FE 45, high resolution)
Correction range	±100 mm (depending on web width, infeed path and web type)
Spreading	0 mm to 5 mm (works setting 5 mm)
Web speed	Max. 50 m/min
Web tension	Max. 500 N
Operating width	300 mm to 2600 mm (roller diameter 160 mm)
Operating voltage	24 V DC
Ambient temperature	+0 to +60 °C
Ambient conditions	Dry and damp
Protection class	IP 54

Selection table

System	Actuator	Area of application	Mounting	Drive	Guiding slat	Sensor	Type of control
SWS9101	SW 9162	Dry, damp	Base	1x drive	Continuous	FE 45	Web center
SWS9103	SW 9162	Dry, damp	Base	1x drive	Continuous	FR 52	Web edge
SWS9105	SW 9162	Dry, damp	Base	1x drive	Continuous	FR 60	Web edge
SWS9151	SW 9170	Dry, damp	Base	1x drive	Sym. segmented with push rod	FE 45	Web center
SWS9153	SW 9170	Dry, damp	Base	1x drive	Sym. segmented with push rod	FR 52	Web edge
SWS9155	SW 9170	Dry, damp	Base	1x drive	Sym. segmented with push rod	FR 60	Web edge
SWS9194	SW 9180	Dry, damp	Base	2x drive	Symmetrically segmented	2xFR 52	Web edge
SWS9196	SW 9180	Dry, damp	Base	2x drive	Symmetrically segmented	2xFR 60	Web edge
SWS9191	SW 9180	Dry, damp	Base	2x drive	Symmetrically segmented	2xFE 45	Web width

All ELSMART products at a glance

Our segmented roller guider systems		
Segmented roller guider system SWA95	You will find a detailed description of this product on page 14.	
Segmented roller guider system SWA95 with spreading system LG 0671	You will find a detailed description of this product on page 15.	
Segmented roller guider system SWA95 with spreading system LG 0671 and rotary tensioner DS 11	You will find a detailed description of this product on page 15.	
Segmented roller guider system SWS95	You will find a detailed description of this product on page 16.	
Segmented roller guider system SWS95 with spreading system LG 0671	You will find a detailed description of this product on page 17.	
Segmented roller guider system SWS95 with pneumatic selvage opener LP 03	You will find a detailed description of this product on page 17.	
Segmented roller guider system SWS94	You will find a detailed description of this product on page 18.	
Segmented roller guider system SWS94 with SW9430 and center support	You will find a detailed description of this product on page 19.	
Segmented roller guider system SWS96	You will find a detailed description of this product on page 20.	
Segmented roller guider system SWS96 with spreading device LG 0673	You will find a detailed description of this product on page 21.	
Segmented roller guider system SWS97	You will find a detailed description of this product on page 22.	
Segmented roller guider system SWS97 with spreading device LG 05	You will find a detailed description of this product on page 23.	
Segmented roller guider system SWS91	You will find a detailed description of this product on page 24.	

Web tension control ELTENS

Function

Load cells measure the actual web tension on the moving web. This value is compared with the target web tension and transferred as a control difference to the PID controller. The PID controller forms the speed correction signal $\pm \Delta v$, which is added to the web speed signal. The corrected target speed is fed to the additional drive on the segmented roller guider. The change in the peripheral speed on the segmented roller guider controls the web tension to the next drive.

Area of use

Using web tension control, knitted and woven fabrics are fed to the next process with the correct web tension and the bearing friction as well as mass inertia of the roller compensated. Due to the required wrapping of 90° , segmented roller guiders cannot be used as a transport drive.

Application

It is to be ensured that the web tension control on a segmented roller guider is integrated correctly into the machine's drive structure. Both before and after the segmented roller guider, the web tension should be maintained constant by means of web tension control or dancer position control. In the most common applications, the segmented roller guider is in front of the main drive, in this case the locking roller can be designed as a measuring roller. If the segmented roller guider is integrated into the machine after a main drive, the infeed roller is to be defined as a measuring roller.

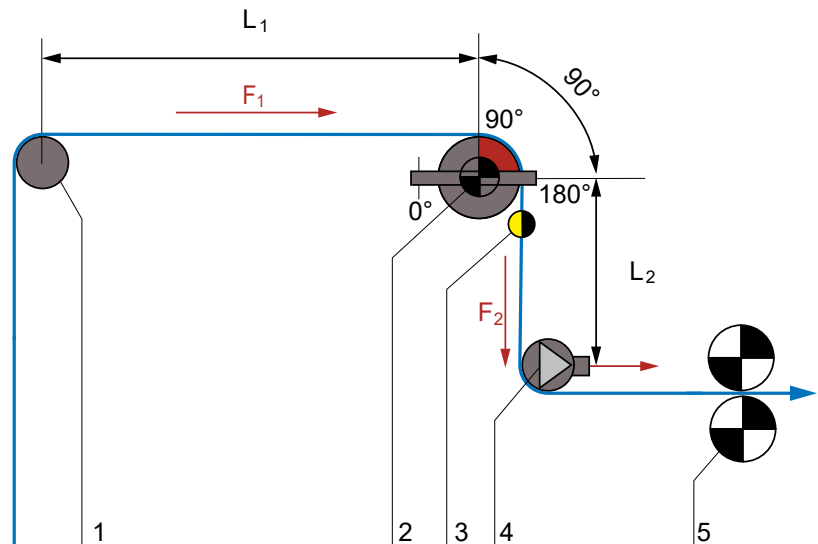

Legend

- 1 Infeed roller
- 2 Segmented roller guider with additional drive
- 3 Edge sensor
- 4 Flange load cell
- 5 Main drive
- L₁ Infeed path
- L₂ Exit path
- F₁ Web tension infeed
- F₂ Web tension exit

Flange load cell PD 25

- Cost-effective aluminum flange load cell
- Compatible with the PD 21/22 standard series
- Multi-position, easy installation due to various mounting options, e.g. flange bearings, pedestal bearings, inner or outer fastening
- Maximum operational reliability due to overload protection up to 10 times the nominal measuring force
- With horizontal measuring direction, the weight of the roller does not affect the measured result
- Good temperature behavior and a high degree of linearity of the measuring elements due to strain gauge application on a flat surface
- High permissible operating speed of the measuring roller due to high web load cell spring constant



Flange load cell PD 25

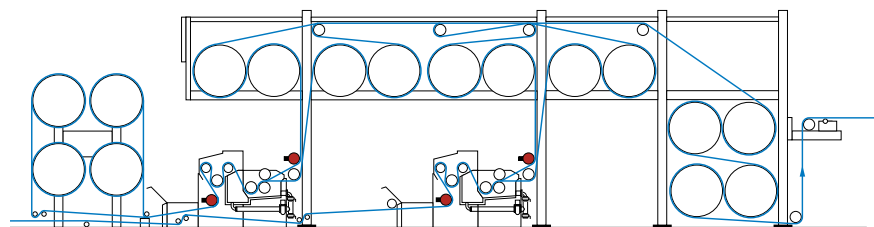

Flange load cell PD 25 on sizing machine

Selection table

Type bore on one side	Ø (mm)	Nominal measuring force (kN)		
PD 2517	17	0.1	0.2	0.5
PD 2525	25	0.15	0.3	0.75
PD 2535	35	0.3	0.6	1.5



Flange load cell PD 25 on the infeed to a sizing bath

Technical data

Accuracy class	1
Nominal characteristic value (sensitivity)	1m V/V
Combined error	< 1 %
Characteristic value tolerance	0.2 %
Measuring principle	Full bridge strain gauge
Nominal resistance of the strain gauge bridge	700 Ohm
Bridge supply voltage, nominal value	10 V
Max. permissible value	14 V
Mechanical stop	1.8 to 2.4 F _N dep. on type
Operating load	1.8 to 2.4 F _N
Limit load	10 x F _N
Nominal measuring deflection	0.1 mm to 0.25 mm depending on type
Nominal temperature range	-10 °C to +60 °C
Operating temperature range	-10 °C to +90 °C
Temperature coefficient	±0.5 % / 10 K (characteristic value), ±0.5 % / 10 K (zero signal)
Protection class	IP 54
Max. permissible axial lateral force	1 x F _N
Weight	0.8 kg (Ø = 17 mm), 1.25 kg (Ø = 25 mm), 2.94 kg (Ø = 35 mm)

Flange load cell PD 23

- Flange load cell in stainless steel for difficult ambient conditions, e.g. washing machines and bleaching systems
- Multi-position, easy installation due to various mounting options, e.g. flange bearings, pedestal bearings, inner or outer fastening
- Maximum operational reliability due to over-load protection up to 20 times the nominal measuring force
- With horizontal measuring direction, the weight of the roller does not affect the measured result
- Good temperature behavior and a high degree of linearity of the measuring elements due to strain gauge application on a flat surface
- High permissible operating speed of the measuring roller due to high web load cell spring constant

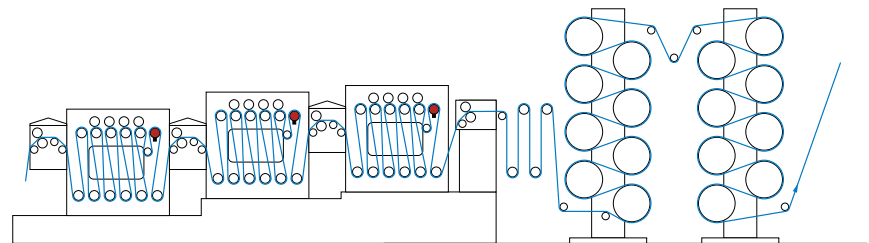

Flange load cell PD 23 on dyeing system

Selection table

Type bore on one side	Type bore on both sides	Ø (mm)		Nominal measuring force (kN)		
PD 2317	PD 2417	17	0.1	0.2	0.5	1
PD 2325	PD 2425	25	0.15	0.3	0.75	1.5
PD 2335	PD 2435	35	0.3	0.6	1.5	3



Flange load cell PD 23 on washing machine

Technical data

Accuracy class	0.5
Nominal characteristic value (sensitivity)	1m V/V
Combined error	< 0.5 %
Characteristic value tolerance	0.2 %
Measuring principle	Full bridge strain gauge
Nominal resistance of the strain gauge bridge	700 Ohm
Bridge supply voltage, nominal value	10 V
Max. permissible value	14 V
Mechanical stop	1.8 to 2.4 F _N dep. on type
Operating load	1.8 to 2.4 F _N
Limit load	20 x F _N
Nominal measuring deflection	0.1 mm to 0.2 mm depending on type
Nominal temperature range	-10 °C to +60 °C
Operating temperature range	-10 °C to +90 °C
Temperature coefficient	± 0.3 % / 10 K (characteristic value), ± 0.3 % / 10 K (zero signal)
Protection class	IP 65
Max. permissible axial lateral force	1 x F _N
Weight	2.3 kg (Ø = 17 mm), 3.6 kg (Ø = 25 mm), 8.5 kg (dØ = 35 mm)

Measuring amplifier CV 22

- Single-channel measuring amplifier for connecting one or two fabric tension sensors with a strain gauge bridge
- Precision instrument amplifier with low temperature drift, high long-term stability and excellent linearity
- With potentiometer for zero point and tare adjustment as well as gain setting
- Internal reference voltage for measuring amplifier calibration without reference weights given exact knowledge of the wrapping angle and mounting position



Measuring amplifier CV 22

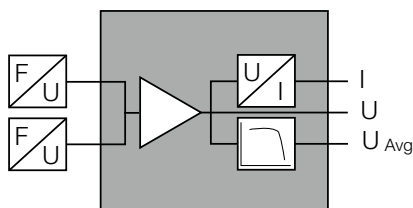

Block diagram CV 22

Technical data	
Technology	1-channel analog precision amplifier for strain gauge full bridge in 4-wire technology
Accuracy class	0.1
Bridge supply voltage	10 V DC stabilized adjusted 9 V to 13 V DC
Input voltage	0 mV to ± 20 mV
Gain range	0: 990 V/V to 3400 V/V 1: 400 V/V to 1250 V/V 2: 600 V/V to 2050 V/V 3: 300 V/V to 1025 V/V
Output signals	
Voltage	0 V to ± 10 V (rise time 5 ms)
Voltage filtered	0 V to ± 10 V (rise time 2 s)
Current	0/4 mA to 20 mA (rise time 5 ms)
Temperature coefficient	
of the nominal value	± 0.3 %/10 K
of the zero signal	± 0.3 %/10 K
of the bridge supply voltage	± 0.04 %/10 K
Operating voltage	
Nominal value	24 V DC
Nominal range	20 V to 30 V DC
Current consumption	0.2 A
Ambient temperature	0 °C to +60 °C
Relative humidity	15 % to 95 % (non-condensing)
Protection rating	
Top-hat rail mounting to DIN EN 50022	IP 00
With housing	IP 54, optional 65

Web tension controller DC 62

The web tension controller has a variable controller structure to cover a wide variety of applications:

- "Open-loop" with diameter signal
- "Closed-loop" via load cell or dancer position: unwinders with electrical and pneumatic brakes; rewinders, unwinders or transport drive with electrical drives

The integrated measuring amplifier, the analog inputs and outputs and the power output stage for electrical brakes make a compact design possible. The menu-based, language-neutral commissioning wizard combined with the color touch display guarantee very straightforward, quick commissioning of the web tension control system. Integration in the customer's controller is ensured with the Ethernet interface.

Other features

- Adaptive control
- 30 recipes
- Configurable winding characteristic (taper tension)
- Alarm function

Application

The DC 62 is universally suitable for all web tension control tasks regardless of whether in the paper, film or textile industrial sectors.



Web tension controller DC 62

Selection table			
Type	Plug-in	Housing	Ethernet
DC 6200	■		■
DC 6201		■	■
DC 6210	■		
DC 6211		■	

Technical data

Operating voltage	24 V DC (20 V to 30 V DC)
Current consumption	0.3 A/4.3 A (elec. brake)
Nominal operating temperature	10 °C to 50 °C
Control cycle time	1 ms
Strain gauge amplifier	2 channels
Input voltage	± 30 mV / 14 bits
Bridge supply voltage	10 V
Analog inputs	
Guiding value/target value/dancer position	2 x 0 V to ± 10 V / 14 bits
Diameter	1 x 0 V to 10 V / 12 bits
Analog outputs	
Electrical brake / coupling	PWM current output 0 to 4 A/ 24 V
Controller actuating signal	1 x 0 V to ±10 V / 14 bits 1 x 0/4 mA to 20 mA
Monitor output	1 x 0 V to 10 V / 12 bits
Digital inputs	3 x floating "0" signal: - 5 V to +2 V "1" signal : + 8 V to +30 V
Digital outputs	2 x floating / short-circuit proof
Output voltage	24 V / max. 0.5 A
CAN interface	250 kBaud
Ethernet interface (UDP)	RJ 45, 100 Mbit/s
Dimensions (W x H x D) /	
DC 6200 plug-in	100 x 100 x 8 (60) mm
DC 6201 housing	130 x 155 x 106 mm
Protection class, plug-in	IP 20
Protection class, housing	IP 54

Additional drives for segmented roller guider

- Additional drive with speed-controlled three-phase geared motor in flange version
- Compensation of the mass inertia and bearing friction on segmented roller guiders
- Usage on longitudinally elastic fabric webs, e.g. knitted fabrics with Lycra
- Can be combined with web tension control so that the fabric web enters the next process with the correct web tension
- Optionally with frequency converter in housing or with switch panel for control cabinet installation



Additional drive AW 10_2



Additional drive AW 11_3



Additional drive AW 11_4



Additional drive AW 12_4



Additional drive AW 19_4 with frequency converter

Technical data and selection table

Type	V (m/min)	Mounting	For segmented roller guider	Power	Operating voltage	Current consumption
AW 1002	1.5 to 50	Flange with coupling	SWS94	0.55 kW	3 x 220 - 240 / 380 - 420 V 50 Hz 3 x 254 - 277 / 440 - 480 V 60 Hz	3 x 2.63 - 2.67 / 1.52 - 1.54 50 Hz 3 x 2.6 - 2.63 / 1.5 - 1.52 60 Hz
AW 1012	4 to 130	Flange with coupling	SWS94	1.1 kW	3 x 220 - 240 / 380 - 420 V 50 Hz 3 x 254 - 277 / 440 - 480 V 60 Hz	3 x 4.2 - 4.17 / 2.43 - 2.38 50 Hz 3 x 3.69 - 3.66 / 2.13 - 2.11 60 Hz
AW 1022	7 to 200	Flange with coupling	SWS94	1.1 kW	3 x 220 - 240 / 380 - 420 V 50 Hz 3 x 254 - 277 / 440 - 480 V 60 Hz	3 x 4.2 - 4.17 / 2.43 - 2.38 50 Hz 3 x 3.69 - 3.66 / 2.13 - 2.11 60 Hz
AW 1103	1.5 to 50	Flange with coupling	SWS95/SWA95	0.55 kW	3 x 220 - 240 / 380 - 420 V 50 Hz 3 x 254 - 277 / 440 - 480 V 60 Hz	3 x 2.63 - 2.67 / 1.52 - 1.54 50 Hz 3 x 2.6 - 2.63 / 1.5 - 1.52 60 Hz
AW 1113	4 to 130	Flange with coupling	SWS95/SWA95	1.1 kW	3 x 220 - 240 / 380 - 420 V 50 Hz 3 x 254 - 277 / 440 - 480 V 60 Hz	3 x 4.2 - 4.17 / 2.43 - 2.38 50 Hz 3 x 3.69 - 3.66 / 2.13 - 2.11 60 Hz
AW 1123	7 to 200	Flange with coupling	SWS95/SWA95	1.1 kW	3 x 220 - 240 / 380 - 420 V 50 Hz 3 x 254 - 277 / 440 - 480 V 60 Hz	3 x 4.2 - 4.17 / 2.43 - 2.38 50 Hz 3 x 3.69 - 3.66 / 2.13 - 2.11 60 Hz
AW 1104	1.5 to 50	Hollow shaft with torque arm	SWS95/SWA95	0.55 kW	3 x 220 - 240 / 380 - 420 V 50 Hz 3 x 254 - 277 / 440 - 480 V 60 Hz	3 x 2.63 - 2.67 / 1.52 - 1.54 50 Hz 3 x 2.6 - 2.63 / 1.5 - 1.52 60 Hz
AW 1114	4 to 130	Hollow shaft with torque arm	SWS95/SWA95	1.1 kW	3 x 220 - 240 / 380 - 420 V 50 Hz 3 x 254 - 277 / 440 - 480 V 60 Hz	3 x 4.2 - 4.17 / 2.43 - 2.38 50 Hz 3 x 3.69 - 3.66 / 2.13 - 2.11 60 Hz
AW 1124	7 to 200	Hollow shaft with torque arm	SWS95/SWA95	1.1 kW	3 x 220 - 240 / 380 - 420 V 50 Hz 3 x 254 - 277 / 440 - 480 V 60 Hz	3 x 4.2 - 4.17 / 2.43 - 2.38 50 Hz 3 x 3.69 - 3.66 / 2.13 - 2.11 60 Hz
AW 1204	1.5 to 50	Hollow shaft with torque arm	SWS96/SWS97	0.55 kW	3 x 220 - 240 / 380 - 420 V 50 Hz 3 x 254 - 277 / 440 - 480 V 60 Hz	3 x 2.63 - 2.67 / 1.52 - 1.54 50 Hz 3 x 2.6 - 2.63 / 1.5 - 1.52 60 Hz
AW 1214	4 to 130	Hollow shaft with torque arm	SWS96/SWS97	1.1 kW	3 x 220 - 240 / 380 - 420 V 50 Hz 3 x 254 - 277 / 440 - 480 V 60 Hz	3 x 4.2 - 4.17 / 2.43 - 2.38 50 Hz 3 x 3.69 - 3.66 / 2.13 - 2.11 60 Hz
AW 1904	5 to 70	Hollow shaft with torque arm	SWS93	0.37 kW	3 x 380 V - 480 V 50/60 Hz	3 x 2.3 A
AW 1914	14 to 130	Hollow shaft with torque arm	SWA95/SWS95/ SWS96/SWS97	1.1 kW	3 x 380 V - 480 V 50/60 Hz	3 x 3.1 A

Ambient temperature: 0 °C to +50 °C (AW 19: 0 °C to +40 °C), ambient conditions: dry and damp, protection class: IP 55

Spreading device LG 067

- Compact spreading system for reliable spreading of folded edges and curled edges on dry to wet woven and knitted fabrics, in painted steel or stainless steel version
- Infinitely adjustable spreading effect due to contra-rotating spreading rollers with pivoting bearings
- No residual soiling due to specific profile shape
- Optimal spreading effect with profile radius of 1 mm for all knitted and woven fabrics
- No markings on the web due to overlapping profiles in the center of the roller



Spreading device LG 067

Application notes

- Free infeed path L_1 should be at least one web width
- The exit path L_2 is to be kept as short as possible
- The direction of rotation of the spreading rollers must be against the direction of web travel
- Adjustable spreading effect due to pivoting the spreading rollers synchronously into the web plane

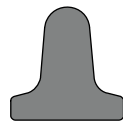

Profile shape (R=1 mm)

Legend

- L_1 Infeed path to the spreading device
- L_2 Exit path from the spreading device
- 1 Rotary tensioner
- 2 Spreading device
- 3 Segmented roller guider
- 4 Sensor
- 5 Locking roller

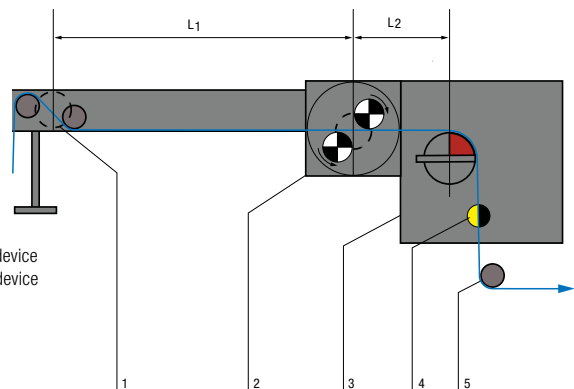

Selection table

Type	Area of application	Housing material
LG 0671	Dry and damp	Painted steel
LG 0673	Wet	Stainless steel V2A (AISI 304)

Technical data

Operating width AB	1000 mm to 3600 mm (steps of 100 mm)
Diameter of the spreading rollers	86 mm (AB 1000 mm to 2400 mm) 112 mm (AB 2500 mm to 3600 mm)
Winding	48/96 mm (standard)
Pitch	2/4 (standard)
Number of spirals	1 mm
Profile radius	1 mm
Ambient temperature	+10 °C to +60 °C
Speed of spreading rollers	268 1/min (50 Hz) 322 1/min (60 Hz)
Nominal power	1x 0.55 kW
Operating voltage	3 x 220 V – 240/380 V – 420 V 50 Hz 3 x 254 V – 277/440 V – 480 V 60 Hz
Current consumption	3 x 2.63 A – 2.67 A / 1.52 A – 1.54 A 50 Hz 3 x 2.6 A – 2.63 A / 1.5 A – 1.52 A 60 Hz
Protection class	IP 55

Spreading device LG 052

- Compact spreading system for reliable spreading of folded edges and curled edges on dry to wet woven and knitted fabrics, in painted steel or stainless steel version, suitable for installation in closed washing machines or steamers
- Infinitely adjustable spreading effect due to contra-rotating spreading rollers with pivoting bearings
- Ambient temperature/conditions: +100 °C, damp, wet and saturated steam
- No residual soiling due to specific profile shape
- Optimal spreading effect with profile radius of 1 mm for all knitted and woven fabrics
- No markings on the web due to overlapping profiles in the center of the roller

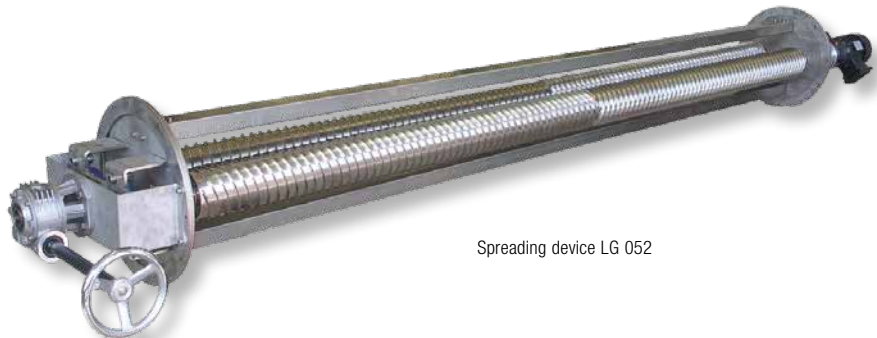

Spreading device LG 052

Application notes

- Free infeed path L₁ should be at least one web width
- The exit path L₂ is to be kept as short as possible
- The direction of rotation of the spreading rollers must be against the direction of web travel
- Adjustable spreading effect due to pivoting the spreading rollers synchronously into the web plane

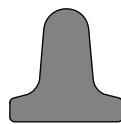

Profile shape (R=1 mm)

Legend

- L₁ Infeed path to the spreading device
- L₂ Exit path from the spreading device
- 1 Spreading device
- 2 Segmented roller guider
- 3 Sensor
- 4 Locking roller

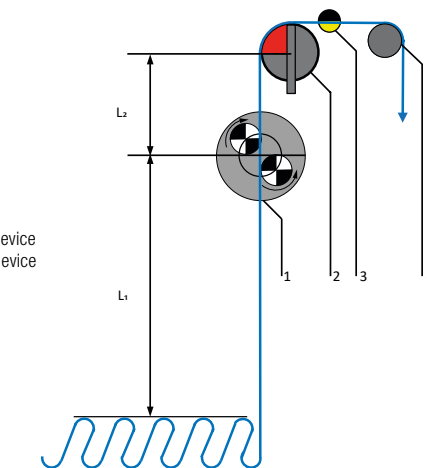

Selection table		
Type	Area of application	Housing material
LG 0523	Wet / steamer	Stainless steel V2A (AISI 304)
LG 0524	Wet / steamer	Stainless steel V4A (AISI 316)

Technical data	
Operating width AB	1600 mm to 3600 mm
Diameter of the spreading rollers	112 mm
Spreading spirals	
Pitch	48/96 mm
Number of spirals	4
Profile radius	1 mm
Ambient temperature	In steamer +0 °C to +100 °C (outside +0 °C to +60 °C)
Ambient conditions	Damp, wet, saturated steam
Speed of spreading rollers	245 1/min (50 Hz) 295 1/min (60 Hz)
Nominal power	2x 0.55 kW
Operating voltage	220 V – 240/380 V – 420 V 50 Hz 254 V – 277/440 V – 480 V 60 Hz
Current consumption	3 x 2.2 A – 2.21 / 1.27 A – 1.3 A 50 Hz 3 x 2.2 A – 2.21 / 1.27 A – 1.3 A 60 Hz
Protection class	IP 55

Spreading roller BG

- Stainless steel spreading roller for reliable spreading of folded edges and curled edges on dry to wet woven and knitted fabrics
- No residual soiling due to specific profile shape
- Optimal spreading effect with profile radius of 1 mm for all knitted and woven fabrics with counter-rotating operation
- No markings on the web

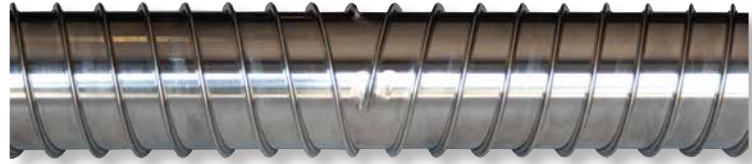

Spreading roller BG

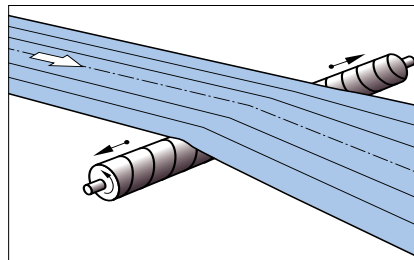

Profile molds

Standard version

Pitch 96 mm, 4-thread

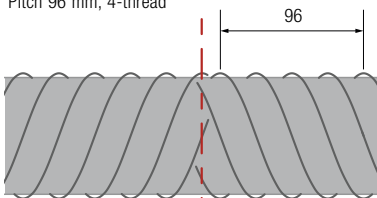

Option

Pitch 48 mm, 2-thread

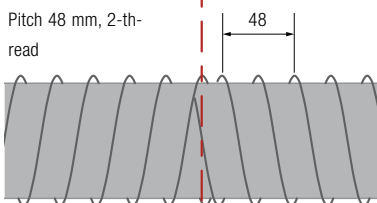

Option

Pitch 48 mm, 4-thread

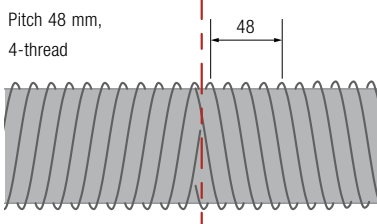

Technical data

Nominal width NB	
Ø 86 mm	600 mm to 2600 mm
Ø 112 mm	600 mm to 3800 mm
Ø 130 mm	600 mm to 4200 mm
Spreading roller diameter	86 / 112 / 130 mm
Spreading spirals	
Pitch	48/96 mm
Number of spirals	2/4
Profile radius	1 mm
Concentricity	0.5 mm/m
Balance quality	Static
Roller body and roller profile material	Stainless steel V2A (AISI 304) Stainless steel V4A (AISI 316)
Roller journal material	Steel Stainless steel V2A (AISI 304) Stainless steel V4A (AISI 316)

Type	Ø (mm)	Material Roller body	Axle material	Profile radius (mm)	Profile material
BG 1086	86	Stainless steel V2A (AISI 304)	Steel	1.0	V2A (AISI 304)
BG 2086	86	Stainless steel V2A (AISI 304)	Stainless steel V2A (AISI 304)	1.0	V2A (AISI 304)
BG 5086	86	Stainless steel V4A (AISA 316)	Stainless steel V4A (AISA 316)	1.0	V4A (AISI 316)
BG 1112	112	Stainless steel V2A (AISI 304)	Steel	1.0	V2A (AISI 304)
BG 2112	112	Stainless steel V2A (AISI 304)	Stainless steel V2A (AISI 304)	1.0	V2A (AISI 304)
BG 5112	112	Stainless steel V4A (AISA 316)	Stainless steel V4A (AISA 316)	1.0	V4A (AISI 316)
BG 1130	130	Stainless steel V2A (AISI 304)	Steel	1.0	V2A (AISI 304)
BG 2130	130	Stainless steel V2A (AISI 304)	Stainless steel V2A (AISI 304)	1.0	V2A (AISI 304)
BG 5130	130	Stainless steel V4A (AISA 316)	Stainless steel V4A (AISA 316)	1.0	V4A (AISI 316)

Pneumatic selvedge opener LP 03

- Pneumatic selvedge opener for opening delicate knitted fabrics
- Optionally with air nozzles in the bottom, top and on both sides
- Optimized selvedge opening effect due to adjustable spacing between the top and bottom plates
- Spring-mounted top plate so seams can pass through without problems

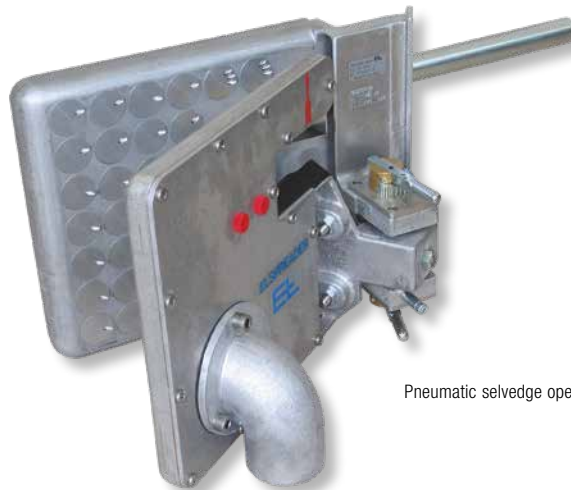

Pneumatic selvedge opener LP 03

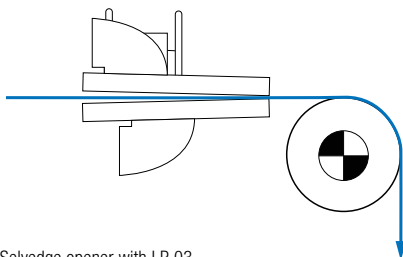

Selvedge opener with LP 03

Technical data

Web type	Woven and knitted fabrics
Web state	Dry, damp, wet
Web speed	Max. 150 m/min
Web weight	Max. 400 g/m ²
Ambient temperature	Max. 80 °C
Spreading force at 75 mbar operating pressure	Approx. 2.3 N

Blower

Differential pressure	190 mbar
Power	2.2 kW 50 Hz/ 2.55 kW 60 Hz
Operating voltage	3 x 200 V - 240 / 345 V - 415 V 50 Hz 3 x 220 V - 275 / 380 V - 480 V 60 Hz
Current consumption	3 x 9.7 / 5.6 A 50 Hz 3 x 10.3 / 6 A 60 Hz
Protection class	IP 54

Selection table

Type	Nozzle mounting	Blower
LP 0301	Bottom plate	1 (for 2 bottom plates)
LP 0302	Top plate	1 (for 2 top plates)
LP 0303	Bottom and top plate	2 (for 2 bottom and top plates)

Integrated web width measurement

- Web width measurement using infrared wide band sensor FE 45 integrated into the segmented roller guider with electrical actuating drive
- Width value can be read as analog value or via fieldbus
- Measuring accuracy dependent on the wide band sensor
 - Standard: ± 10 mm
 - High: ± 6 mm
 - Premium: ± 2 mm



Segmented roller guider SWS95 with wide band sensor FE 45

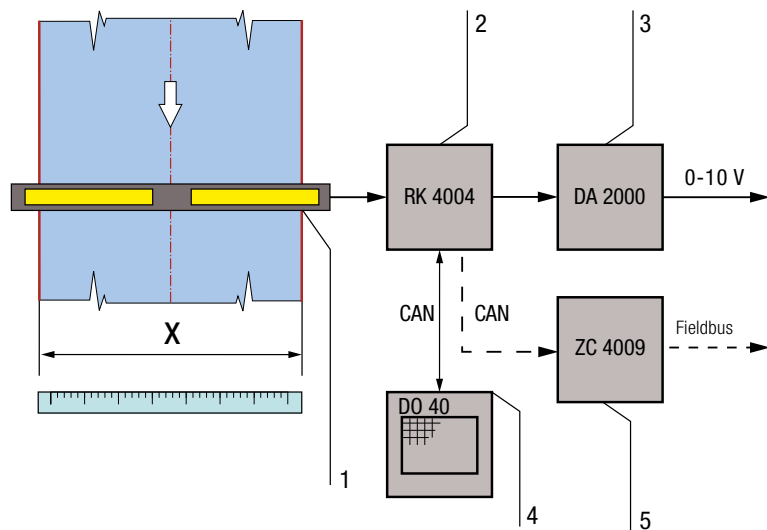

Legend

- | | | | |
|---|----------------------------------|---|------------------------|
| 1 | Wide band sensor FE 45 | 2 | Control module RK 4004 |
| 3 | Digital-analog converter DA 2000 | 4 | Command station DO 40 |
| 5 | Interface ZC 4009 | X | Web width |

"Stand alone" web width measurement

- Web width measurement FES45 with infrared wide band sensor FE 45 and command station DO 48 for independent mounting in the machine
- Indication of target and actual width on the command station
- Width monitoring with adjustable tolerances including alarm output
- Measuring accuracy dependent on the wide band sensor



Wide band sensor FE 45



Command station DO 48

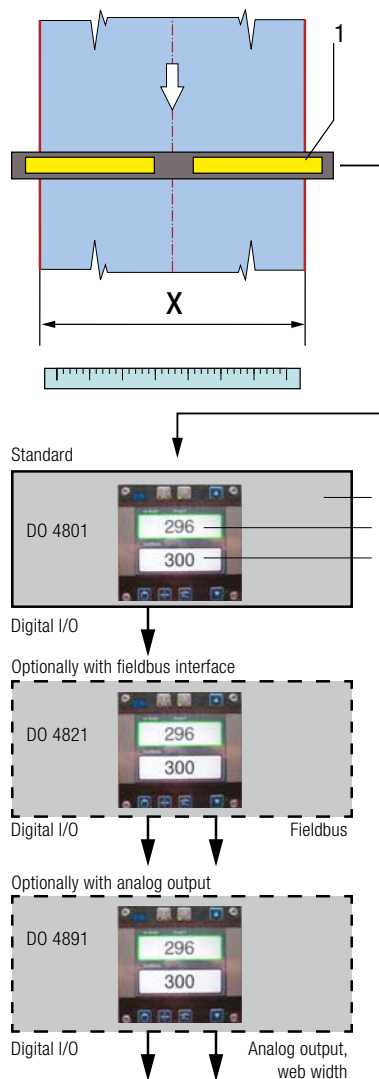

Legend

- 1 Wide band sensor FE 45
- 2 Command station DO 4801
- 3 Actual web width
- 4 Target web width
- X Web width

Technical data

Measuring range	2x 900 mm to 2x 1700 mm
Operating width	Min. 400 mm, max. 3800 mm
Clear width	Plexiglas 80 mm, glass 75 mm
Width measurement accuracy	Standard ± 10 mm, High ± 6 mm, Premium ± 2 mm
Web plane (height fluctuation)	Max. ± 10 mm around the sensor center axis
Operating voltage	24 V DC (20 V to 30 V DC)
Current consumption	1 A
Inputs	2x Sensor CAN
Digital outputs	Upper/lower alarm limit Upper/lower pre-warning limit Width ok, width deviation Fault indication
Analog output DO 4891	Configurable 0 V to +10 V DC/-10 V to +10 V DC, 0 mA to +20 mA/+4 mA to +20 mA/0 to +10 mA
Fieldbus DO 4821	2x CAN BUS /protocol 2.0 2x Ethernet /protocol UDP / Ethernet IP
Dimensions (LxWxH)	300x150x80 mm
Ambient temperature	+10 °C to +50 °C
Protection class	IP 54

Selection table, command control

Type	Option
DO 4801	Standard
DO 4821	2x Ethernet /protocol UDP / Ethernet IP / M12
DO 4891	2x analog output, configurable

Selection table, width measuring system

Type	Measuring accuracy	Material
FES4571	± 10 mm	Plexiglas
FES4581	± 6 mm	Plexiglas
FES4591	± 2 mm	Plexiglas
FES4573	± 10 mm	Glass
FES4583	± 6 mm	Glass
FES4593	± 2 mm	Glass

Function of steering roller system ELSWING

A roller arrangement consisting of two web guiding rollers pivots around an imaginary pivot point in the infeed plane immediately in front of the actuator. Immediate corrections are made via the lateral movement. The additional skewed positioning provides continuous correction of the moving web. Here, friction-locking between the web and the roller is required.

The steering roller systems are used predominantly in textile production systems for web guiding and spreading, where they are used for woven fabrics only.

The length of the infeed depends on the web properties. In the case of very flexible webs, the infeed should be at least one web width.

The greater the surface stability of the web and the greater the necessary corrections, the longer the infeed needs to be. By contrast, the outfeed plane to the locking roller downstream must be kept short. Vertical web travel is imperative.

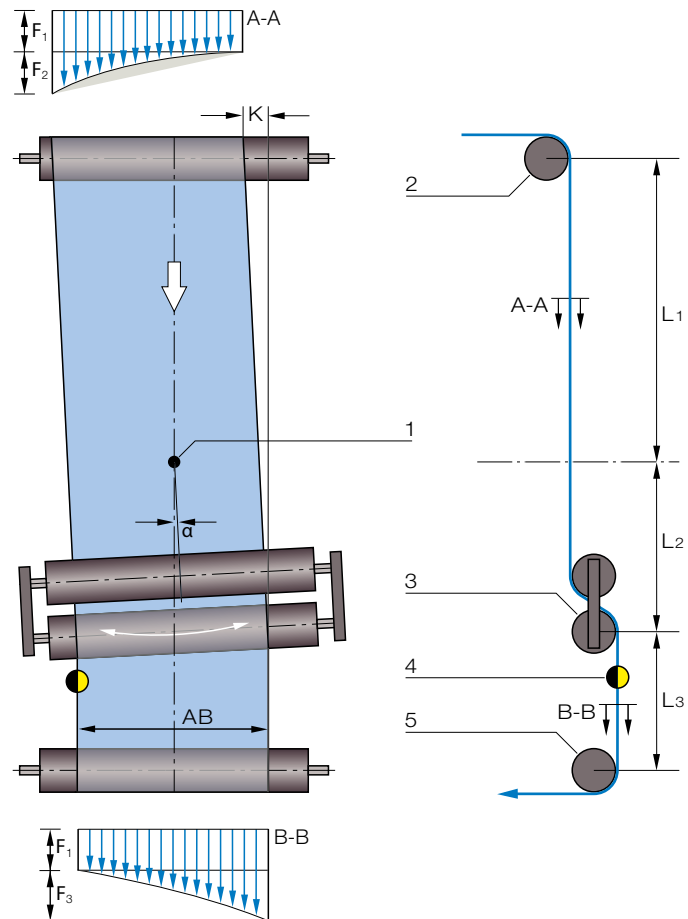

Legend

A-A	Web tension distribution at the infeed	L1	Infeed path to pivot point
B-B	Web tension distribution at the exit	L2	Infeed path from pivot to guide roller
K	Web correction	L3	Exit path
AB	Operating width	α	Correction angle
F ₁	Basic web tension	1	Imaginary pivot point
F ₂	Web tension distribution due to the deflection of the steering roller at the infeed	2	Infeed roller/rod
F ₃	Web tension distribution due to the deflection of the steering roller at the exit	3	Steering frame
		4	Sensor
		5	Locking roller

Steering roller system SRA83

- Steering roller system for guiding dry or damp woven or knitted fabric by web center or web edge
- Integrated edge acquisition using wide band sensor by web center or web edge
- Optionally with spreading device for spreading folded webs and curled edges
- Spreading rollers infinitely adjustable
- Guard with Plexiglas sliding doors and safety switches for clear view and direct access to the web



Steering roller system SRA83

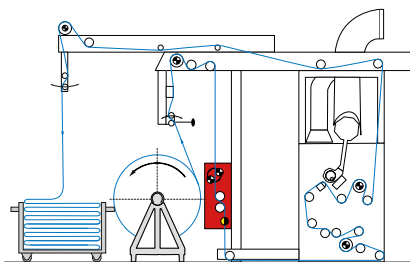

Steering roller system SRA83
in the infeed on a shearing machine

Technical data

Positional accuracy	±25 mm
Web type	Woven and knitted fabrics
Web state	Dry, damp and wet
Operating width	1600 mm to 3400 mm
Web tension	Max. 1000 N
Web speed	Max. 150 m/min
Actuating speed	40 mm/s
Operating voltage	24 V DC
Operating pressure actuating drive	4 bar to 6 bar
Ambient temperature	+0 °C to +60 °C
Protection class	IP 54

Selection table

Type	Type of control	Sensor	Spreading device	Area of application
SRA8301	Web center	FE 45 Plexiglas	without	Dry Damp
SRA8302	Web edge	FE 45 Plexiglas	without	Dry Damp
SRA8311	Web center	FE 45 Plexiglas	with LG 0671	Dry Damp
SRA8312	Web edge	FE 45 Plexiglas	with LG 0671	Dry Damp
SRA8361	Web center	FE 45 glass	without	Wet
SRA8362	Web edge	FE 45 glass	without	Wet
SRA8351	Web center	FE 45 glass	with LG 0673	Wet
SRA8352	Web edge	FE 45 glass	with LG 0673	Wet

Web guiding with web guider ELTWIN

Function

In the web guiding system, the web edge is scanned mechanically by a sensor lever or without contact using optoelectronics. The sensor signal controls a diaphragm cylinder or a lifting magnet that presses the control roller against the counterpressure roller. The web edge is controlled by the skewed positioning and contact pressure of the web guiding rollers. The web guiders have a compact design and are always used in pairs. A support beam is available in various versions for positioning the web guiders.

Area of use

Web guiding systems are used for web guiding in textile production plants for woven and knitted fabrics.

Application

Vertical web travel is imperative for web guiders. The infeed path should be at least one web width. By contrast, the exit path to the locking roller should be kept as short as possible.

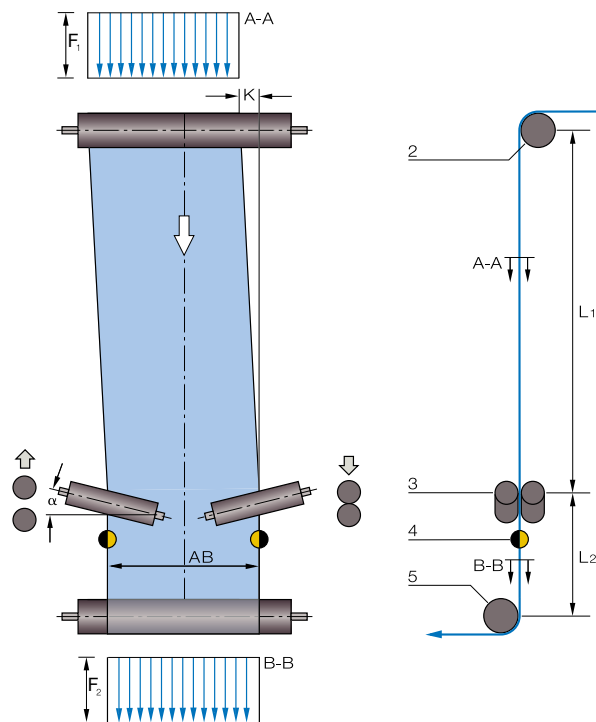

Legend

A-A	Web tension distribution at the infeed	2	Infeed roller/rod
B-B	Web tension distribution at the exit	3	Web guider
K	Web correction	4	Sensor
α	Correction angle	5	Locking roller
F ₁	Web tension at the infeed	L ₁	Infeed path
F ₂	Web tension at the exit	L ₂	Exit path
AB	Operating width		



Web guider KF 2020 in the infeed in a textile calender

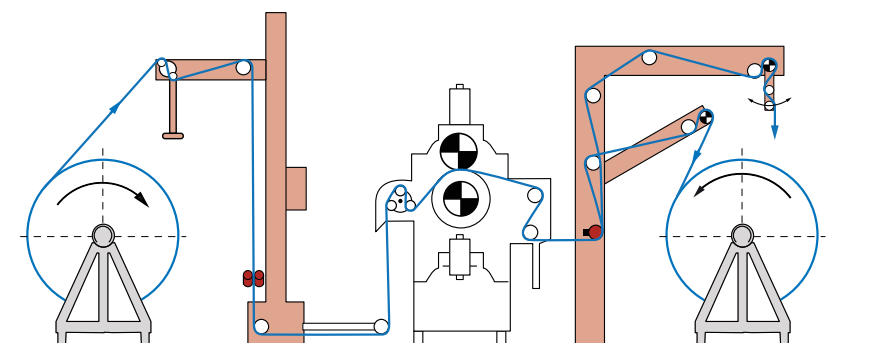

Web guider KF 2020 in the infeed in a textile calender

Web guider KF 20

Mechanical web guider KF 2020

- With pneumatic operation for the control of dry or moist woven fabrics
- Very cost-effective and robust web guiding
- Infinitely adjustable roller distance
- Infinitely adjustable sensor lever contact force and roller contact force

Electrical web guider KF 2040

- With mechanical edge acquisition for the control of dry or moist woven fabrics
- Very cost-effective and robust web guiding
- Infinitely adjustable roller distance
- Infinitely adjustable sensor lever contact force

Electrical web guider KF 2060

- With optoelectronic edge acquisition for the control of dry or damp woven or knitted fabrics
- Infinitely adjustable roller distance

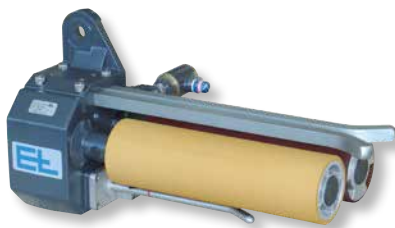

Mechanical web guider KF 2020

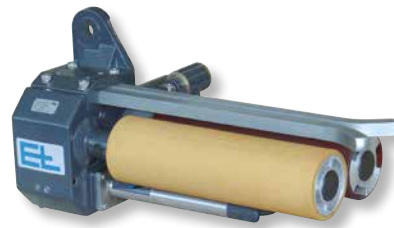

Electrical web guider KF 2040



Electrical web guider KF 2060

Technical data			
Type	KF 2020	KF 2040	KF 2060
Positional accuracy	±1 mm	±1 mm	±1 mm for woven fabrics / ±5 mm for knitted fabrics
Web type	Woven fabric	Woven fabric	Woven and knitted fabrics
Web state	Dry and damp (drained)	Dry and damp (drained)	Dry and damp (drained)
Web width			
For roller length 280 mm	650 mm to 3500 mm	650 mm to 3500 mm	650 mm to 3500 mm
For roller length 400 mm	900 mm to 4500 mm	900 mm to 4500 mm	900 mm to 4500 mm
Web speed	Max. 200 m/min	Max. 200 m/min	Max. 200 m/min
Web weight	Max. 500 g/m ²	Max. 500 g/m ²	Max. 500 g/m ²
Ambient temperature	+0 °C to +60 °C	+0 °C to +60 °C	+0 °C to +60 °C
Operating voltage	-	3x 400 V 50/60 Hz	3x 400 V 50/60 Hz
Control voltage	-	32 V DC	32 V DC
Power consumption	-	Approx. 0.066 kW/pair	Approx. 0.066 kW/pair
Air pressure	0.5 bar to 2 bar	-	-
Air consumption	Approx. 0.6 m ³ /h per pair	-	-
Protection class	-	IP 65	IP 65

Support beam VWG for web guider

Support beam VWG1

- Support beam for positioning web guiders with short rollers
- Symmetrical positioning of the web guider
- Mounting as a flange or pedestal bearing



Support beam VWG1

Support beam VWG2

- Support beam with torque arm for positioning web guiders with long rollers
- Symmetrical positioning of the web guider
- Manual or motorized adjustment possible
- Mounting as a flange or pedestal bearing



Support beam VWG2

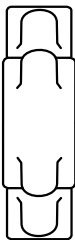

x1 Pedestal bearing

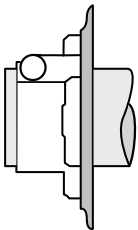

x2 Flange bearing, inner

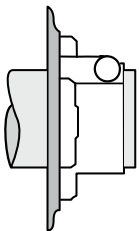

x3 Flange, outer

Technical data

Type	Positioning/sliding guides	Mounting
VWG1 A-X1-K3		Pedestal bearing
VWG1 A-X2-K3	Symmetrically adjustable	Flange bearing, inner
VWG1 A-X3-K3		Flange bearing, outer
VWG1 AB-X1-K3		Pedestal bearing
VWG1 AB-X2-K3	Individually and symmetrically adjustable	Flange bearing, inner
VWG1 AB-X3-K3		Flange bearing, outer
VWG2 A-X1-K3		Pedestal bearing
VWG2 A-X2-K3	Symmetrically adjustable	Flange bearing, inner
VWG2 A-X3-K3		Flange bearing, outer
VWG2 AB-X1-K3		Pedestal bearing
VWG2 AB-X2-K3	Individually and symmetrically adjustable	Flange bearing, inner
VWG2 AB-X3-K3		Flange bearing, outer

Selection table

Type	VWG1	VWG2
Load bearing capacity per sliding guide	<25 kg	<40 kg
Actuating travel per revolution	10 mm	10 mm
Tube surface	Chrome-plated	

Questionnaire

General data

Customer

Street

Zip code

City/town

Country

Internet

Phone

Fax

Contact person

Telephone (direct)

E-mail

Project

Technical data

Type of machine

Make

Position on the machine

Web type

Woven fabric Knitted fabric Non-woven fabric Foam material

Web surface

Not transparent Transparent

Web edge

Straight Frayed Wavy Curled

Web width

Min. mm Max. mm

Printing width

Min. mm Max. mm

Web thickness

Min. mm Max. mm

Web weight

Min. g/m² Max. g/m²

Web speed

Min. m/min Max. m/min

Web tension

Min. N Max. N

Condition in operation

Dry Damp Wet

Ambient temperature

°C

Ambient conditions

Dry Wet Alkali, acidic

Infeed error

± mm

Web infeed

From the car or J-box From the A-frame Inside the machine

Positional accuracy

Desired ± mm

Operating pressure

bar

Reference voltage

For machine speed, additional drive

0 V - 10 V DC

Control voltage

24 V DC

 V

Operating voltage

3x V

Hz

Technical specifications, segmented roller guider, application in general

<input type="checkbox"/> Segmented roller guider	Type of control	<input type="checkbox"/> By web edge	<input type="checkbox"/> Manual sensor positioning <input type="checkbox"/> Motorized sensor positioning <input type="checkbox"/> Wide band sensor			
		<input type="checkbox"/> By web center	<input type="checkbox"/> With wide band sensor <input type="checkbox"/> Motorized sensor positioning			
		<input type="checkbox"/> Oscillation	± mm			
		<input type="checkbox"/> Width measurement	Desired accuracy ± mm			
	Sensor	<input type="checkbox"/> Infrared edge sensor	<input type="checkbox"/> Infrared wide band sensor			
	Mounting	<input type="checkbox"/> Box	<input type="checkbox"/> Base	<input type="checkbox"/> Flange		
	Facing	<input type="checkbox"/> Mohair	<input type="checkbox"/> PVC	<input type="checkbox"/> Stainless steel, bare	<input type="checkbox"/> Stainless steel with nubs	<input type="checkbox"/> Stainless steel, perforated profile
	Spreading	<input type="checkbox"/> With spreading				
	Additional drive	<input type="checkbox"/> With additional drive	<input type="checkbox"/> Provided by customer			
		<input type="checkbox"/> Additional drive attachment	<input type="checkbox"/> Hollow shaft (standard)	<input type="checkbox"/> Flange		
		<input type="checkbox"/> With frequency converter	<input type="checkbox"/> Frequency converter provided by customer			
	Spreading device	<input type="checkbox"/> With mechanical spreading device	<input type="checkbox"/> With hand wheel	<input type="checkbox"/> Hand wheel length	mm	
			<input type="checkbox"/> With crank handle			
			<input type="checkbox"/> 600 mm	<input type="checkbox"/> 800 mm	<input type="checkbox"/> 1200 mm	
	Rotary tensioner	<input type="checkbox"/> With rotary tensioner	Length mounting bracket			
			<input type="checkbox"/> 1200 mm (standard)	<input type="checkbox"/> 800 mm	<input type="checkbox"/> 1400 mm	
			<input type="checkbox"/> With hand wheel	Hand wheel length		mm
<input type="checkbox"/> With crank handle						
<input type="checkbox"/> 600 mm			<input type="checkbox"/> 800 mm	<input type="checkbox"/> 1200 mm		
Installation	<input type="checkbox"/> Without crank handle					
	According to company standard NOR-SW-555721					
Command station	<input type="checkbox"/> Command station with switch	<input type="checkbox"/> Switch from customer				
	<input type="checkbox"/> Command station with display	Cable length controller - command station				
		<input type="checkbox"/> 5 m	<input type="checkbox"/> 10 m	<input type="checkbox"/> m		
Interface	<input type="checkbox"/> Web offset	Cable length				
		<input type="checkbox"/> 5 m	<input type="checkbox"/> 10 m	<input type="checkbox"/> m		
		<input type="checkbox"/> Profibus DP	<input type="checkbox"/> Ethernet IP			
Interface	<input type="checkbox"/> Digital I / O	Cable length command station - interface				
		<input type="checkbox"/> 5 m	<input type="checkbox"/> 10 m	<input type="checkbox"/> m		

Technical specification, segmented roller guider, application on printing machine

<input type="checkbox"/> Segmented roller guider	Type of control	<input type="checkbox"/> By web edge	<input type="checkbox"/> Manual sensor positioning	<input type="checkbox"/> Motorized sensor positioning	
		<input type="checkbox"/> By web center	<input type="checkbox"/> Manual sensor positioning	<input type="checkbox"/> Motorized sensor positioning	
		<input type="checkbox"/> By target width	<input type="checkbox"/> Manual sensor positioning	<input type="checkbox"/> Motorized sensor positioning	
	Sensor	<input type="checkbox"/> Infrared edge sensor	<input type="checkbox"/>		
	Mounting	<input type="checkbox"/> Box	<input type="checkbox"/> Base		
	Facing	<input type="checkbox"/> Mohair	<input type="checkbox"/> PVC		
	Spreading	<input type="checkbox"/> With spreading	<input type="checkbox"/> Symmetrical profiles		
			<input type="checkbox"/> Asymmetrical profiles		
			<input type="checkbox"/> 200 mm	<input type="checkbox"/> 300 mm	<input type="checkbox"/> 400 mm
	Additional drive	<input type="checkbox"/> With additional drive	<input type="checkbox"/> Provided by customer		
		Additional drive attachment	<input type="checkbox"/> Hollow shaft (standard)	<input type="checkbox"/> Flange	
		<input type="checkbox"/> With frequency converter	<input type="checkbox"/> Frequency converter provided by customer		
	Selvedge opening device	<input type="checkbox"/> With pneumatic selvedge opening device	<input type="checkbox"/> Curled edge bottom	<input type="checkbox"/> Curled edge top	<input type="checkbox"/> Curled edge both sides
	Installation arrangement	According to company standard NOR-SW-555721			
Command station	<input type="checkbox"/> Command station with switch		<input type="checkbox"/> Switch from customer		
	<input type="checkbox"/> Command station with display	<input type="checkbox"/> Cable length controller - command station			
		<input type="checkbox"/> 5 m	<input type="checkbox"/> 10 m	<input type="checkbox"/> m	
	<input type="checkbox"/> Web offset	Cable length			
<input type="checkbox"/> 5 m		<input type="checkbox"/> 10 m	<input type="checkbox"/> m		
Interface	<input type="checkbox"/> Digital I / O	<input type="checkbox"/> Profibus DP		<input type="checkbox"/> Ethernet IP	
		Cable length command station - interface			
		<input type="checkbox"/> 5 m	<input type="checkbox"/> 10 m	<input type="checkbox"/> m	

Technical specification, steering roller

<input type="checkbox"/> Steering roller	Spreading device	<input type="checkbox"/> Without	<input type="checkbox"/> With
	Control voltage	<input type="checkbox"/> 24 V DC	<input type="checkbox"/> With power supply unit
	Installation	According to company standard NOR-SR_83 - 555723	

Technical specification, web guider

<input type="checkbox"/> Web guider	Support beam	<input type="checkbox"/> Symmetrical adjustment	<input type="checkbox"/> Individual adjustment
		<input type="checkbox"/> Pedestal bearing mounting	<input type="checkbox"/> Frame external dimension mm
		<input type="checkbox"/> Flange bearing mounting	<input type="checkbox"/> Frame internal dimension mm
			<input type="checkbox"/> Frame external dimension mm
		<input type="checkbox"/> With pneumatic hose for KF 2020	

Comments

Date	Issuer
------	--------

Other products for the textile industry

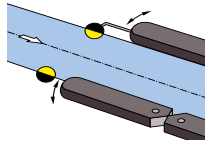

ELFEED – Tenter infeed systems

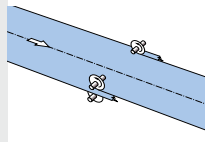

ELCUT – Web cutting systems

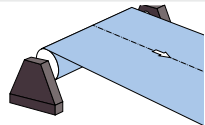

ELWEBTEX – Infeed and exit systems for textile production processes

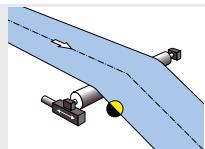

ELBANDER – Fabric position control systems

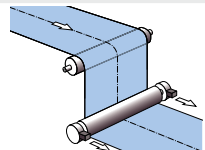

ELTENS – Web tension control systems

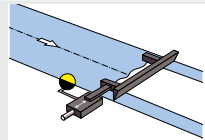

ELPOSER – Positioning and follow-up control systems

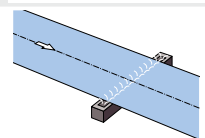

ELMETA – Metal detection systems

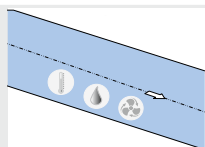

ELMAT – Process control systems for tenters

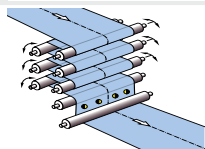

ELSTRAIGHT – Textile straightening systems

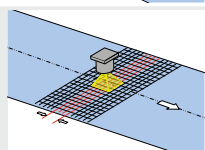

ELCOUNT – Pick and course counter system

Head office

Erhardt+Leimer GmbH
Albert-Leimer-Platz 1 · 86391 Stadtbergen, Germany
Phone: +49 (0)821 2435-0
info@erhardt-leimer.com · www.erhardt-leimer.com

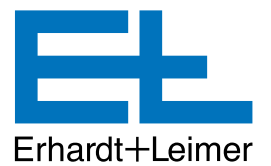

Subsidiaries

E+L Elektroanlagen Augsburg, Germany · E+L Steuerungstechnik St. Egidien, Germany
E+L Bradford, England · E+L Mulhouse, France · E+L Stezzano, Italy · E+L Bucharest, Romania
E+L Barcelona, Spain · E+L Burlington, Canada · E+L Duncan, S.C., USA · E+L Guarulhos-São Paulo, Brazil
E+L Ahmedabad, India · E+L Hangzhou, China · E+L Tao Yuan, Taiwan Province · E+L Yokohama, Japan
E+L Seoul, Republic of Korea · E+L Bangkok, Thailand

Subject to technical change without notice · GRU--220959-EN-13 · 09/2025 · 363846

