

## ELSTRETCHER

Felt and wire stretchers  
for the paper industry

Fabric tension measuring and control systems

# Contents

---

Higher quality due to fabric tension control	4
The control loop	5
Lever-arm type stretcher SP 09	6
Spindle-type stretcher SP 08	8
Chain-type stretcher SP 10	10
Fabric tension sensor PD 80/90	12
Fabric tension sensor EM 08 for spindle-type stretcher SP 08	13
Fabric tension sensor EM 10 for chain-type stretcher SP 10	14
Measuring amplifier CV 22	16
Digital measuring amplifier PA 62	17
Fabric tension controller DC 04/24	18
Command station DO 20	19
Interfaces	20
Networking	21
Networking with process control system	22
Networking with E+L fabric tension control system	23
Wrap angle compensation	24
Felt cocking unit VM 08/10	26
Accessories	27
Questionnaire 1/2	28
Questionnaire 2/2	29
Services from A – Z	30

FOCUS ON CUSTOMER SATISFACTION

---

INTELLIGENT TECHNOLOGY · SMART PRODUCTS

---

INTERNATIONAL LOCATIONS · WORLDWIDE AVAILABILITY

---

# CUTTING-EDGE TECHNOLOGY AT HOME ALL OVER THE WORLD

**Erhardt+Leimer**  
Global solutions for production of the future

Intelligent technologies and products in the highest quality designed to optimize the production processes of our customers all around the world. This is our claim as the internationally expanding Erhardt+Leimer group of companies.

With our global presence – from development to production and on to service – we are always close to the customer. We develop customer-specific solutions and provide our customers with excellent products either in digital or intelligent versions depending on their preference. Not only this, but we also set new standards for the production of tomorrow. In the process, it is not just our products that are increasingly becoming smart – our entire company is currently undergoing a digital transformation. One visible indication of this is the E+L online shop, which enables our customers to order products and spare parts quickly and easily from our website.

With more than 1,600 employees at sites across Europe, Asia, and America, we deliver cutting-edge technology on-time to any location in the world.

In everything we do, we aim to use all company resources responsibly to protect the environment and demonstrate our commitment to increased sustainability.



## Higher quality due to fabric tension control

Users of paper machine clothing are confronted with ever higher requirements these days:

- It must be possible to realize production processes more quickly and at the same time with greater precision.
- The quality of the result must increase while personnel costs, scrap and machine down-times are to be reduced to a minimum.

Fabric tension control systems make a crucial contribution to meeting these requirements.

Experience tells us that felt and wire are affected by a large number of factors. Excessively high or excessively low fabric tension has a significant effect on the quality and volume of paper production. E+L felt and wire tensioning systems eliminate these potential defects to ensure constant fabric tension during the production process.

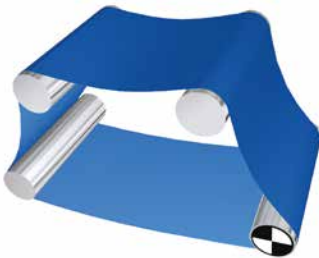

### Excessively low fabric tension

- Reduced drainage capacity in the wire section
- Increased re-moistening in the press section
- High steam consumption in the dryer section
- Tearing due to sheet fluttering in the dryer section
- Clothing abrasion due to slip between clothing and rollers
- Differences in drive/speed
- Negative effect on the fabric guiding



### Excessively high fabric tension

- Roller and bearing damage
- Marks on the paper web
- Contraction in the width of the clothing
- Reduced clothing service life
- Clothing tearing
- Poor formation
- Lower drainage capacity

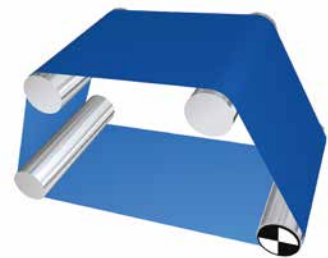

### Constant fabric tension

- Increased quality and paper production volume
- Prerequisite for a long clothing service life
- Improved clothing travel

# The control loop

Any automation of a controller is based on the principle of a simple control loop. Even the most complex of tasks may be reduced to this control loop.

1. The starting point is the actual tension in the moving wire or felt.
2. Fabric tension sensors constantly and precisely acquire the tension in the wire or felt.
3. The controller compares the actual tension with the pre-defined target value and sends a corresponding correction signal to the actuator.
4. The actuator/stretcher positions the stretch roller and in this way corrects the tension in the wire or felt.

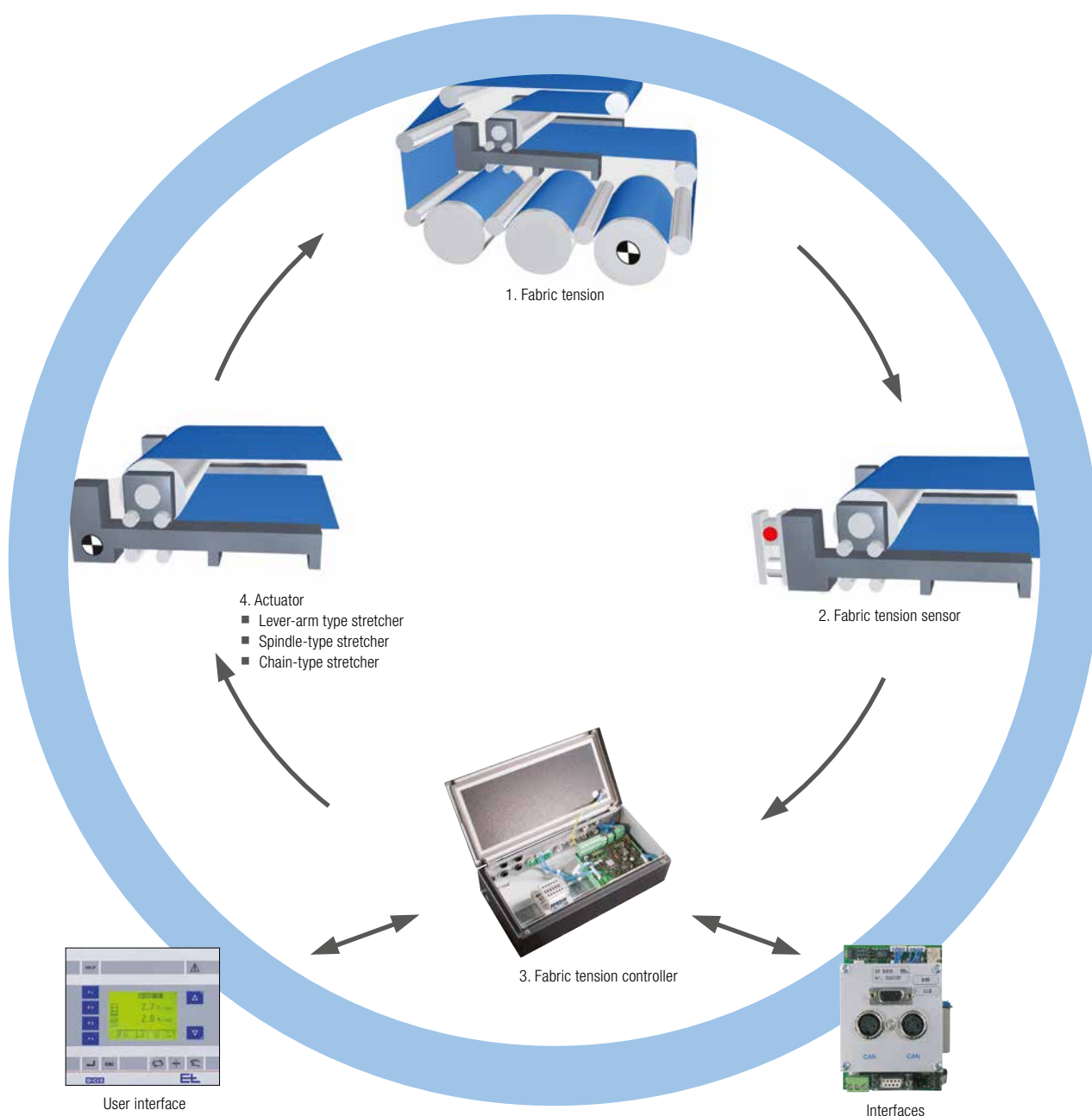

# Lever-arm type stretcher SP 09

## Function

Lever-arm type stretching systems monitor and control the fabric tension of wires. Externally mounted or integrated into the lever-arm type stretcher (with mechanical wrap angle compensation), fabric tension sensors continuously measure the tension. A digital three-point controller continuously compares the actual value with the set target value and sends a correction value to the actuating drive of the lever-arm type stretcher. The tension on the wire is increased or decreased via the lever-arm type stretcher.

## Application

Lever-arm type stretchers can be freely mounted in terms of position. The adjustment stroke should be dimensioned for a 1 to 2 % change in the length of the wire and the necessary length required for changing the wire. The fabric tension sensor is to be installed in the direction of travel of the wire as close as possible to the stretch roller. Only one lever-arm type stretcher can be operated in automatic mode per wire. Additional lever-arm type stretchers are to be positioned "manually".

## Your benefits

- Increased drainage capacity
- Improved sheet forming (formation + retention)
- Increased service life of the wire
- Reduced wire abrasion thanks to reduced slip between the wire and the rollers
- Improved wire guiding due to constant tension
- No wire width contraction
- Avoidance of wire breakage
- In comparison to air bellows, vibration-free adjustment via spindle positioning elements
- Robust design

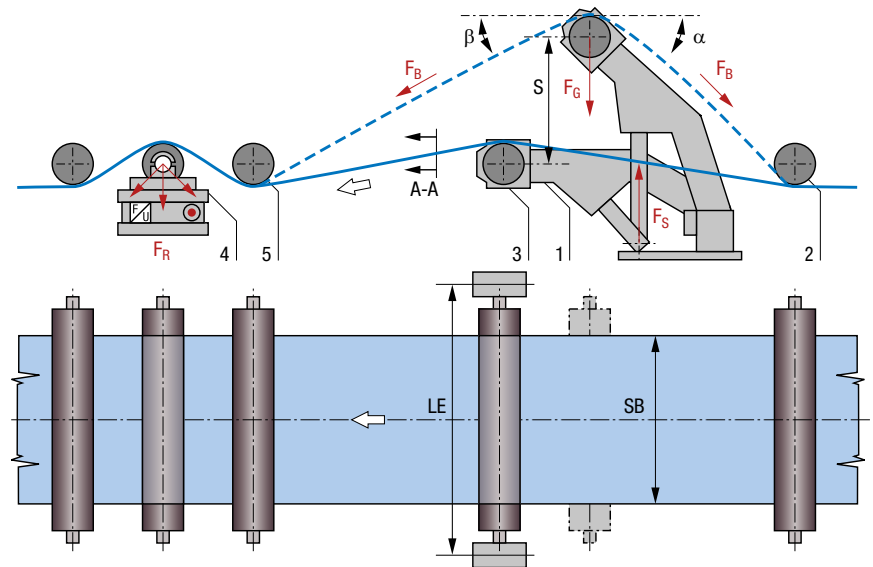

### Legend

SB	Wire width	1	Lever-arm type stretcher
LE	Distance between bearing centers	2	Infeed roller
$\alpha, \beta$	Infeed and outfeed angle	3	Stretch roller
$F_B$	Fabric tension	4	Fabric tension sensor
$F_S$	Actuating force	5	Outfeed roller
$F_G$	Force due to gravity on stretch roller	A-A	Fabric tension distribution
$F_R$	Resulting fabric tension	S	Stretcher stroke

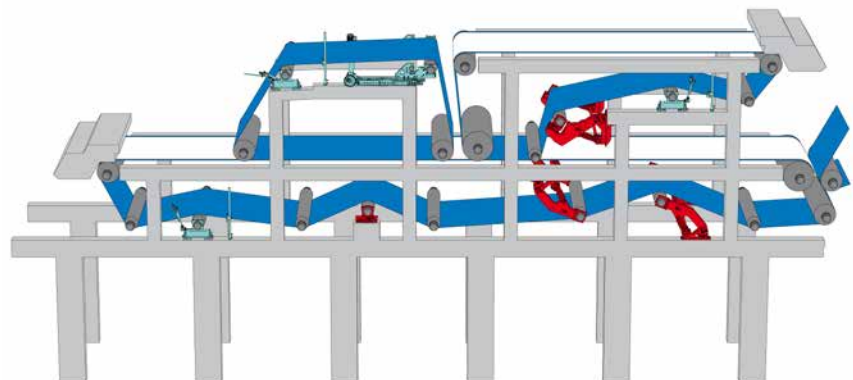

ELSTRETCHER SP 09 in the wire section

- Compact design for wire section
- Parallel adjustment of the stretch roller via self-locking trapezoidal threaded spindle (vibration-free)
- Flexible application due to position-independent installation (standing upright/hanging)
- Stainless steel version
- Adjustable positioning stroke by means of inductive proximity switches
- Optionally with bearing bracket for stretch roller
- Drive with three-phase motor (optionally with pneumatic motor)
- Doctor mounting on customer request
- Optionally with cover for cross shaft

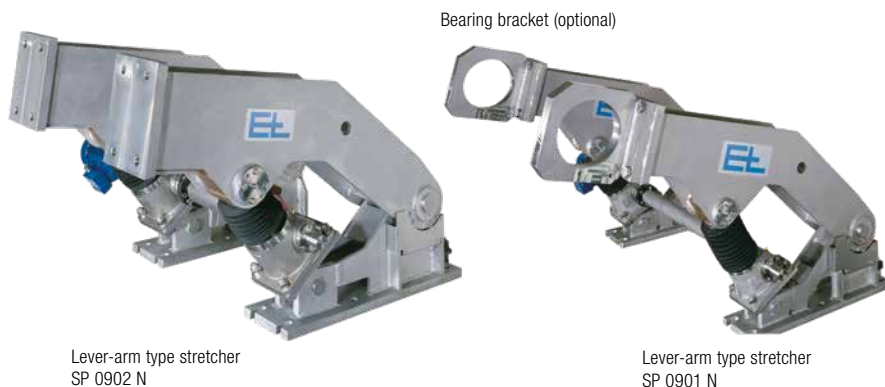

### Technical data

Type	SP 0901 N*	SP 0902 N*
Max. actuating force	35 kN (position dependent)	100 kN (position dependent)
Max. travel	600 mm (without bearing bracket)	750 mm (without bearing bracket)
Actuating speed	Min. 85 mm/min lever extended Max. 147 mm/min lever retracted	Min. 89.5 mm/min lever extended Max. 174 mm/min lever retracted
End position limitation	Inductive proximity switch	Inductive proximity switch
Diameter of bearing bracket (optional)	80 mm to 250 mm	180 mm to 340 mm
Spindle size	TR 50 x 8 mm	TR 65 x 10 mm
Material	Stainless steel	Stainless steel
Area of use	Wet	Wet
Power	0.75 kW	2.2 kW
Operating voltage		
Range 1	220 V - 240 V / 380 V - 420 V 50 Hz / 440 V - 480 V 60 Hz	220 V - 240 V / 380 V - 420 V 50 Hz / 440 V - 480 V 60 Hz
Range 2/3	On request	On request
Current consumption		
Range 1	3.6 A / 2.1 A 50 Hz / 1.9 A 60 Hz	9.0 A / 5.2 A 50 Hz / 9.0 A 60 Hz
Range 2/3	On request	On request
Ambient temperature	+10 °C to +60 °C	+10 °C to +60 °C
Protection rating		
Standard	IP 66	IP 66
Other protection ratings	On request	On request

\* N = Wet

# Spindle-type stretcher SP 08

## Function

Spindle-type stretcher systems monitor and control the fabric tension of revolving felts. Integrated fabric tension sensors measure the fabric tension continuously and instantaneously. A digital three-point controller continuously compares the actual value with the set target value and sends a correction value to the actuating drive. The tension on the felt is increased or decreased via the spindle-type stretcher.

## Application

Spindle-type stretcher systems can be freely mounted in terms of position. Wrapping of  $180^\circ$  is desirable for the stretch roller. The adjusting plane of the spindle-type stretcher should be positioned in the angle bisecting line between the infeed and outfeed. Wrap angle compensation needs to be incorporated if the overall wrapping around the stretch roller is  $<150^\circ$ .

## Your benefits

- Maximum drainage capacity due to optimized water absorption and reduced re-moistening
- Reduced felt markings on the paper
- Increased felt service life
- Ideal solution for applications where space is limited thanks to the trapezoidal threaded spindle that withstands compressive loads
- Reduced felt abrasion due to reduced slip between felt and guide rollers
- Improved felt guiding due to constant tension
- Avoidance of roller and bearing damage during machine standstill (felt drying)
- Reduced felt width contraction
- Avoidance of felt tears

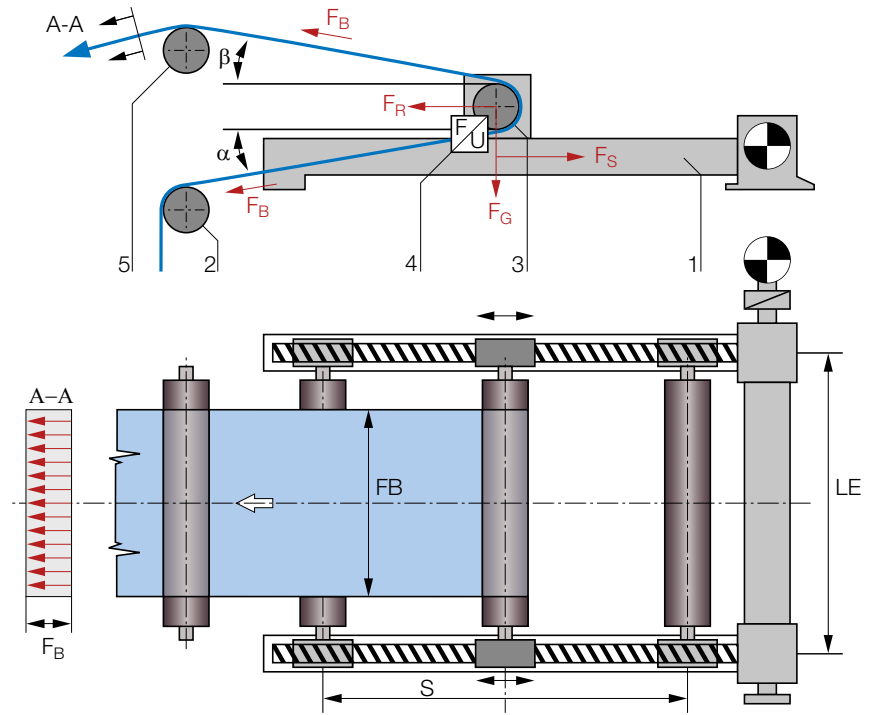

### Legend

FB	Felt width	$F_G$	Force due to gravity on stretch roller	4	Fabric tension sensor
LE	Distance between bearing centers	$F_R$	Resulting fabric tension	5	Outfeed roller
$\alpha, \beta$	Infeed and outfeed angle	1	Spindle-type stretcher	A-A	Fabric tension distribution
$F_B$	Fabric tension	2	Infeed roller	S	Stretcher stroke
$F_S$	Actuating force	3	Stretch roller		

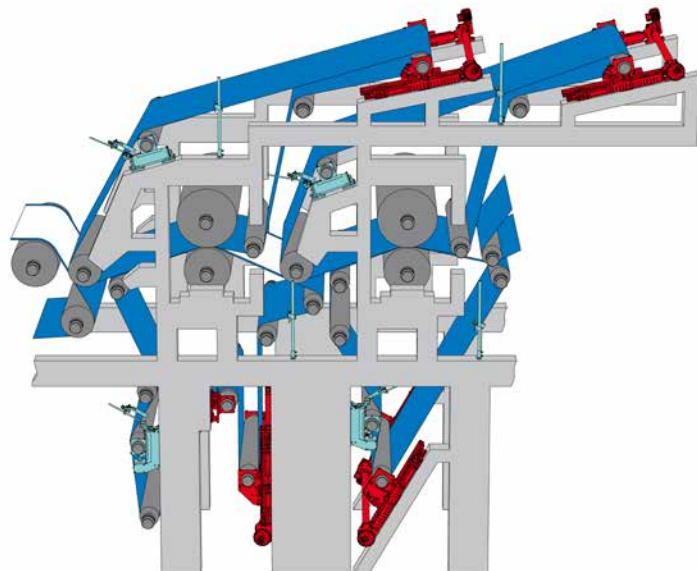

ELSTRETCHER SP 08 in the press section

- Stainless steel spindle-type stretcher for press section (or steel version for dryer section)
- Adjustment of the stretch roller parallel to the axis by means of a self-locking trapezoidal threaded spindle
- Precise fabric tension measurement by fabric tension sensor on one side integrated in the tension carriage (optionally possible on both sides)
- Drive with three-phase motor (optionally with pneumatic motor)
- Spindle can be subjected to tensile and compressive load
- Flexible application due to position-independent mounting (standing upright/hanging)
- Mounting of the stretch roller in a bearing bracket or pedestal bearing
- Bearing bracket cover can be removed
- Seam correction by means of single-sided spindle adjustment with a hand wheel
- Optionally with hinged bearing bracket cover
- Optionally with position sensor FE 07 for acquisition of the position of the stretch roller
- Optionally with cover for cross shaft
- Optionally with pre-wiring
- Optionally with handwheel monitoring
- Optionally with protective plate

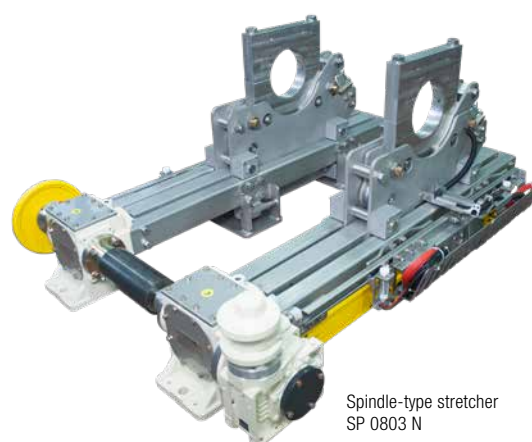
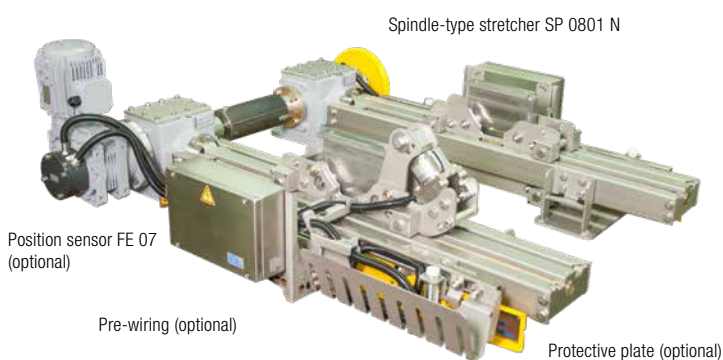

Technical data				
Type	SP 0801 N*	SP 0801 T*	SP 0803 N*	SP 0803 T*
Max. actuating force	45 kN	45 kN	90 kN	90 kN
Max. stretcher stroke	2500 mm	2500 mm	3500 mm	3500 mm
Actuating speed	250 mm/min	250 mm/min	285 mm/min	285 mm/min
End position limitation	Ind. proximity switch	Mech. proximity switch	Ind. proximity switch	Mech. proximity switch
Diameter of bearing bracket	80 mm to 260 mm	80 mm to 260 mm	80 mm to 350 mm	80 mm to 350 mm
Spindle size	TR 40 x 7 mm	TR 40 x 7 mm	TR 50 x 8 mm	TR 50 x 8 mm
Material	Stainless steel	Steel, painted	Stainless steel	Steel, painted
Area of use	Wet	Dry	Wet	Dry
Power	0.75 kW	0.75 kW	1.5 kW	1.5 kW
Operating voltage				
Range 1	200 V - 240 V / 346 V - 420 V 50/60 Hz		200 V - 240 V / 346 V - 420 V 50/60 Hz	
Range 2	230 V - 290 V / 400 V - 500 V 50/60 Hz		230 V - 290 V / 400 V - 500 V 50/60 Hz	
Range 3	290 V - 330 V / 500 V - 575 V 50/60 Hz		290 V - 330 V / 500 V - 575 V 50/60 Hz	
Current consumption				
Range 1	3.3/1.9 A 50 Hz 3.6/2.1 A 60 Hz		6.7/3.9 A 50 Hz 6.1/3.5 A 60 Hz	
Range 2	2.9/1.7 A 50 Hz 3.2/1.9 A 60 Hz		5.3/3.1 A 50 Hz 5.3/3.1 A 60 Hz	
Range 3	2.8/1.6 A 50 Hz 2.7/1.6 A 60 Hz		4.3/2.5 A 50 Hz 4.1/2.4 A 60 Hz	
Ambient temperature				
Standard	+10 °C to +60 °C		+10 °C to +60 °C	
Optional			+10 °C to +130 °C	
			+10 °C to +150 °C	
Protection rating				
Standard	IP 66		IP 66	
Other protection ratings	On request		On request	

\* N = Wet, T = Dry

# Chain-type stretcher SP 10

## Function

Chain-type stretcher systems monitor and control the fabric tension of revolving dry wires. Integrated fabric tension sensors measure the fabric tension continuously and instantaneously. A digital three-point controller continuously compares the actual value with the set target value and sends a correction value to the actuating drive. The tension on the dry wire is increased or decreased via the chain-type stretcher.

## Application

Chain-type stretchers can be freely mounted in terms of position. Wrapping of  $180^\circ$  is desirable for the stretch roller. The adjusting plane of the chain-type stretcher should be positioned in the bisecting line between the infeed and outfeed. Wrap angle compensation needs to be incorporated if the overall wrapping around the stretch roller is  $<150^\circ$ .

## Your benefits

- Increased performance of the dryer section (machine speed)
- Reduced steam consumption in the dryer section due to optimized contact drying
- Reduced paper web tears due to the slip-free drive of the drying cylinder (silent drive)
- No web flutter
- Increased drying fabric service life
- No clothing abrasion due to slip between clothing and rollers
- Improved dryer wire guiding due to constant tension
- Avoidance of roller and bearing damage
- No marking of the paper web due to excessively high fabric tension
- No tearing of the clothing due to excessively high tension

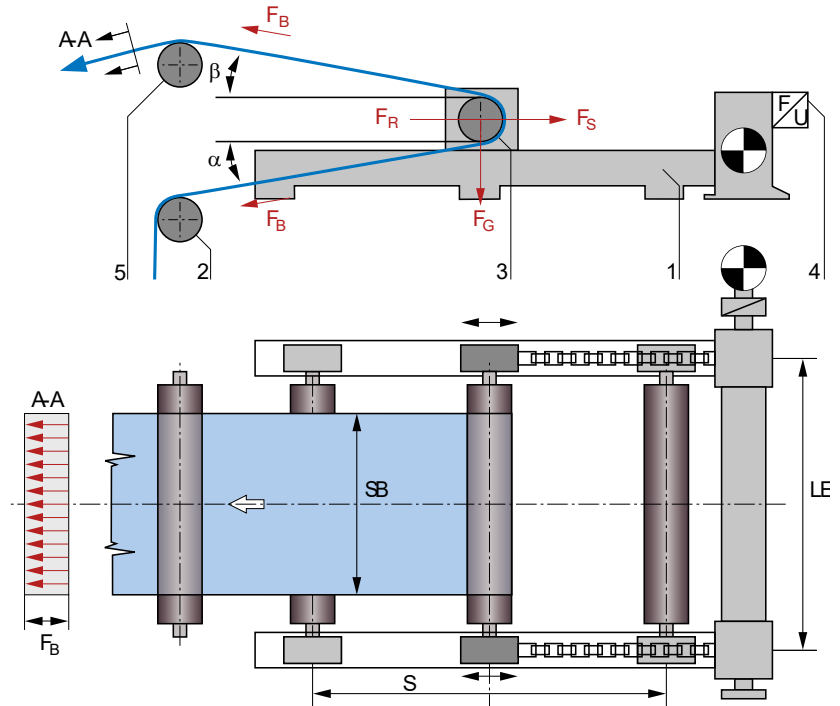

### Legend

SB Wire width  
LE Distance between bearing centers  
 $\alpha, \beta$  Infeed and outfeed angle  
 $F_B$  Fabric tension  
 $F_S$  Actuating force

$F_G$  Force due to gravity on stretch roller  
 $F_R$  Resulting fabric tension  
1 Chain-type stretcher  
2 Infeed roller  
3 Stretch roller

4 Fabric tension sensor  
5 Outfeed roller  
A-A Fabric tension distribution  
S Stretcher stroke

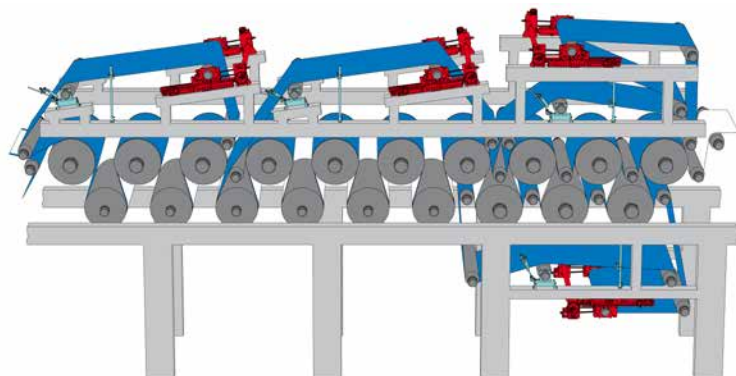

ELSTRETCHER SP 10 in the dryer section

- Steel chain-type stretcher for dryer section (or stainless steel version for press section)
- Adjustment of the stretch roller parallel to the axis using a chain
- Precise fabric tension measurement by means of a fabric tension sensor integrated on one side in the tension carriage or on the gearbox housing (optionally measurement is also possible on both sides)
- Drive with three-phase motor (optionally with pneumatic motor)
- Mechanical locking of the stretch roller by self-locking worm gear
- Flexible application due to position-independent mounting (standing upright/hanging)
- Mounting of the stretch roller in a bearing bracket or pedestal bearing
- Bearing bracket cover can be removed
- Seam correction by means of single-sided chain adjustment with a hand wheel
- Optionally with hinged bearing bracket cover
- Optionally with position sensor FE 07 for acquisition of the position of the stretch roller
- Optionally with cover for cross shaft
- Optionally with pre-wiring
- Optionally with handwheel monitoring
- Optionally with protective plate
- Optionally with motor and handwheel on one side



Chain-type stretcher SP 1001 T

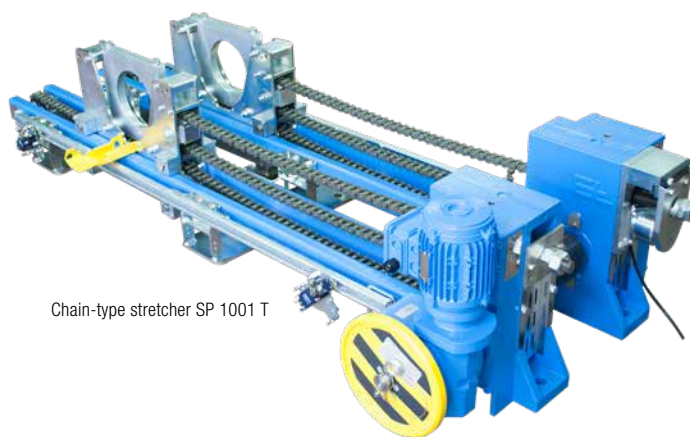

Chain-type stretcher SP 1001 T

### Technical data

Type	SP 1001 N*	SP 1001 T*	SP 1003 N*	SP 1003 T*
Max. actuating force	26 kN	45 kN	43 kN	65 kN
Max. stretcher stroke	2500 mm	2500 mm	3500 mm	3500 mm
Actuating speed	280 mm/min	280 mm/min	280 mm/min	280 mm/min
End position limitation	Ind. proximity switch	Mech. proximity switch	Ind. proximity switch	Mech. proximity switch
Diameter of bearing bracket	80 mm to 260 mm	80 mm to 260 mm	80 mm to 350 mm	80 mm to 350 mm
Chain size	1"	1"	1 1/4"	1 1/4"
Material	Stainless steel	Steel, painted	Stainless steel	Steel, painted
Area of use	Wet	Dry	Wet	Dry
Power	0.75 kW	0.75 kW	0.75 kW	0.75 kW
Operating voltage				
Range 1	200 V - 240 V / 346 V - 420 V 50/60 Hz		200 V - 240 V / 346 V - 420 V 50/60 Hz	
Range 2	230 V - 290 V / 400 V - 500 V 50/60 Hz		230 V - 290 V / 400 V - 500 V 50/60 Hz	
Range 3	290 V - 330 V / 500 V - 575 V 50/60 Hz		290 V - 330 V / 500 V - 575 V 50/60 Hz	
Current consumption				
Range 1	3.3 A / 1.9 A 50 Hz	3.6 A / 2.1 A 60 Hz	3.3 A / 1.9 A 50 Hz	3.6 A / 2.1 A 60 Hz
Range 2	2.9 A / 1.7 A 50 Hz	3.2 A / 1.9 A 60 Hz	2.9 A / 1.7 A 50 Hz	3.2 A / 1.9 A 60 Hz
Range 3	2.8 A / 1.6 A 50 Hz	2.7 A / 1.6 A 60 Hz	2.8 A / 1.6 A 50 Hz	2.7 A / 1.6 A 60 Hz
Ambient temperature				
Standard	+10 °C to +60 °C		+10 °C to +60 °C	
Optional				
Standard				
Optional	+10 °C to +150 °C		+10 °C to +150 °C	
Protection rating				
Standard	IP 66		IP 66	
Other protection ratings	On request		On request	

\* N = Wet, T = Dry

# Fabric tension sensor PD 80/90

- Stainless steel version for wire and press section
- Steel version for dryer section
- Encapsulated pivot point with lifetime lubrication
- Highly reliable in operation thanks to mechanical overload protection
- Different sizes and nominal measuring forces from 1 to 90 kN ensure a high degree of flexibility (optionally in redundant design)
- Robust design prevents zero point drift due to impacts and machine vibration
- Measuring unit easily accessible and easy to replace

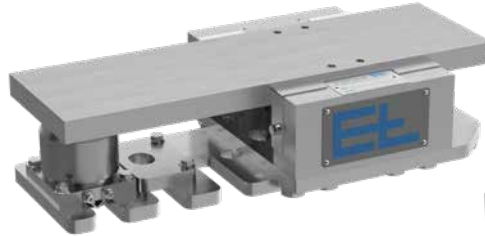

Fabric tension sensor PD 80

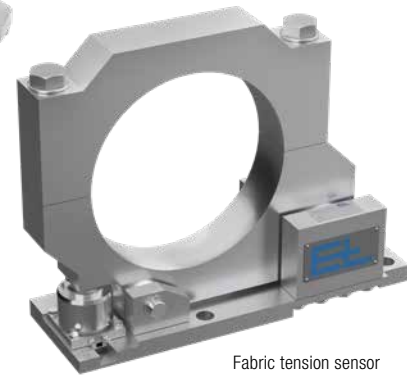

Fabric tension sensor PD 90

### Fabric tension sensor PD 80

- Fabric tension sensor for external measurement on separate guide roller for pedestal bearing mounting

### Fabric tension sensor PD 90

- Fabric tension sensor for external measurement on separate guide roller with bearing bracket
- Design tailored specifically to customer requirements

### Function

Fabric tension sensors PD 80/90 comprise a baseplate and a component mounted on a pivot for mounting the measuring roller in the bearing brackets or a version with a low profile support for pedestal bearing mounting. The tensile forces caused by the fabric act as a moment on the pivot point and generate a measuring force on the measuring unit.

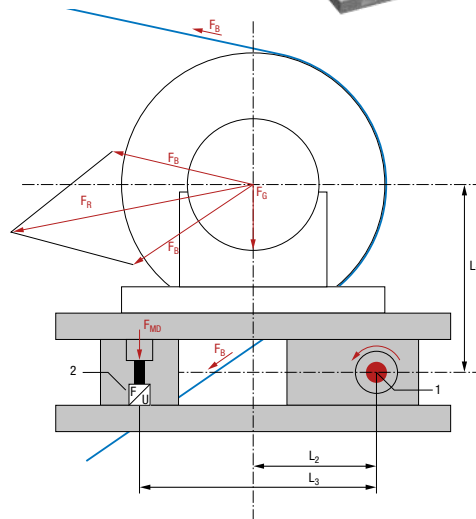

### Legend

- $F_B$  Fabric tension
- $F_R$  Resulting fabric tension
- $F_G$  Force due to gravity on measuring roller
- $F_{MD}$  Resulting fabric tension per fabric tension sensor
- $L_1$  Vertical distance pivot point – middle of roller
- $L_2$  Horizontal distance pivot point – middle of roller
- $L_3$  Distance pivot point – measuring unit
- 1 Pivot point
- 2 Measuring unit

### Area of use

Fabric tension sensors PD 80/90 are used for mounting on separate guide rollers (e.g. for lever-arm type stretchers in the wire section).

### Application

Wrapping and installation must be selected such that the fabric tension sensor is always under pressure. The fabric tension sensor is to be installed in the direction of travel as close as possible to the stretch roller. Optionally, fabric tension sensors can also be mounted on both sides.

### Selection table

Type	Dry	Wet	Size L x W x H	Nominal measuring force $F_N$ (kN)										
PD 80_1	■		300 x 250 x 120 mm	1	2	5	10	20	30					
PD 80_2		■	300 x 250 x 120 mm	1	2	5	10	20	30					
PD 80_3	■		500 x 250 x 120 mm	1	2	5	10	20	30					
PD 80_4		■	500 x 250 x 120 mm	1	2	5	10	20	30					
PD 80_5	■		800 x 410 x 190 mm				10	20	30	40	60	90		
PD 80_6		■	800 x 410 x 190 mm				10	20	30	40	60	90		
PD 90__	■	■	Customer-specific	1	2	5	10	20	30	40	60	90		

# Fabric tension sensor EM 08 for spindle-type stretcher SP 08

- Integrated measurement in spindle-type stretchers
- Pivot point bearing in the tension carriage can be lubricated
- Stainless steel version for press section (optional steel version for dry section)
- Highly reliable in operation thanks to mechanical overload protection
- Different sizes and nominal measuring forces from 1 to 30 kN ensure a high degree of flexibility (optionally in redundant design)
- Robust design prevents zero point drift due to impacts and machine vibration
- Includes cable carrier for fabric tension sensor
- Measuring unit easily accessible and easy to replace

Fabric tension sensor EM 08

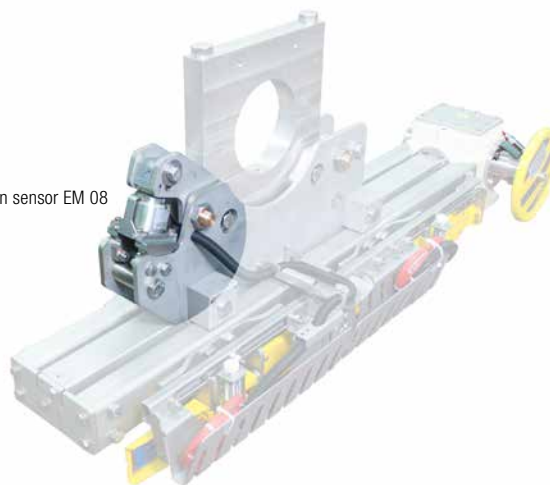

## Function

The tensile forces caused by the fabric act as a moment on the bearing bracket's pivot point and generate a measuring force on the measuring unit.

## Area of use

The fabric tension sensors of the EM 08 series are used in spindle-type stretchers.

## Application

Wrapping of 180° is desirable for the stretch roller. Wrap angle compensation needs to be incorporated if the overall wrapping around the stretch roller is <150°. Optionally, fabric tension sensors can also be mounted on both sides.

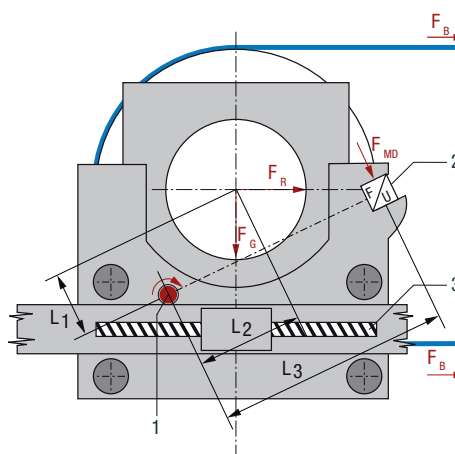

## Legend

$F_B$  Fabric tension

$F_R$  Resulting fabric tension

$F_G$  Force due to gravity on stretch roller

$F_{MD}$  Resulting fabric tension per fabric tension sensor

$L_1$  Vertical distance pivot point – middle of roller

$L_2$  Horizontal distance pivot point – middle of roller

$L_3$  Distance pivot point – measuring unit

1 Pivot point

2 Measuring unit

3 Spindle adjustment

## Selection table

Type	Application	Dry	Wet	Nominal measuring force $F_N$ (kN)					
EM 08__T	SP 08	■		1	2	5	10	20	30
EM 08__N	SP 08		■	1	2	5	10	20	30

# Fabric tension sensor EM 10 for chain-type stretcher SP 10

## Function

### Fabric tension sensor in the tension carriage

The tensile forces caused by the fabric act as a moment on the bearing bracket's pivot point and generate a measuring force on the measuring unit.

### Fabric tension sensor on the gearbox housing

The tensile forces caused by the fabric generate a measuring force on the measuring unit via the chain and a lever arm.

## Area of use

The fabric tension sensors in the EM 10 series are used in chain-type stretchers.

## Application

Wrapping of 180° is desirable for the stretch roller. Wrap angle compensation needs to be incorporated if the overall wrapping around the stretch roller is <150°. Optionally, fabric tension sensors can also be mounted on both sides.

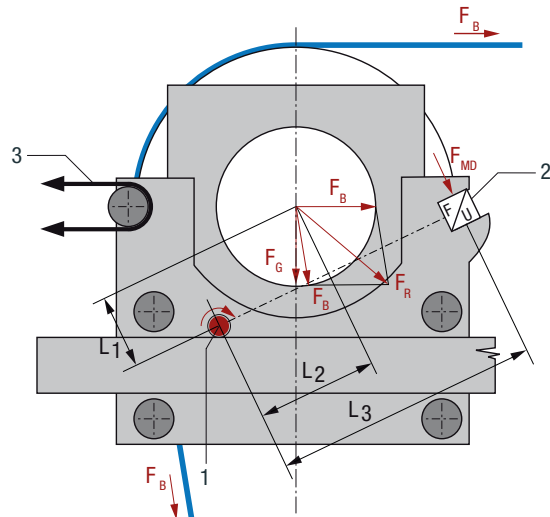

### Legend

$F_B$	Fabric tension	$L_1$	Vertical distance pivot point – middle of roller
$F_R$	Resulting fabric tension	$L_2$	Horizontal distance pivot point – middle of roller
$F_G$	Force due to gravity on stretch roller	$L_3$	Distance pivot point – measuring unit
$F_{MD}$	Resulting fabric tension per fabric tension sensor	1	Pivot point
		2	Measuring unit
		3	Chain adjustment

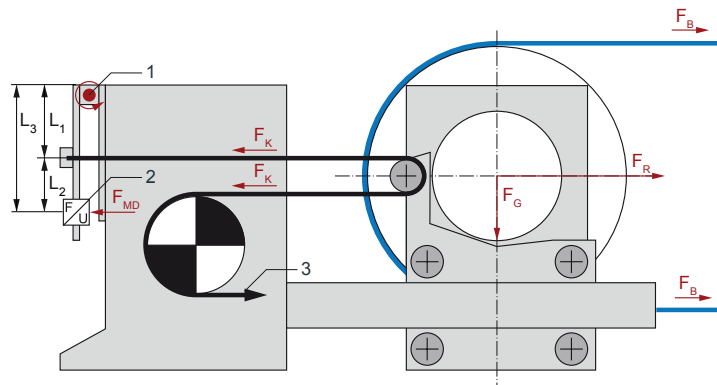

### Legend

$F_B$	Fabric tension	$L_1$	Distance pivot point – chain fastening
$F_R$	Resulting fabric tension	$L_2$	Distance chain fastening – measuring unit
$F_G$	Force due to gravity on stretch roller	$L_3$	Distance pivot point – measuring unit
$F_{MD}$	Resulting fabric tension per fabric tension sensor	1	Pivot point
$F_K$	Tensile force on chain	2	Measuring unit
		3	Chain adjustment

- Integrated measurement in chain-type stretchers
- Pivot point bearing in the tension carriage can be lubricated
- Steel version for the dry section (optional stainless steel version for press section)
- Highly reliable in operation thanks to mechanical overload protection
- Different sizes and nominal measuring forces from 1 to 30 kN ensure a high degree of flexibility (optionally in redundant design)
- Robust design prevents zero point drift due to impacts and machine vibration
- Includes cable carrier for fabric tension sensor
- Measuring unit easily accessible and easy to replace



Fabric tension sensor EM 10 in the tension carriage

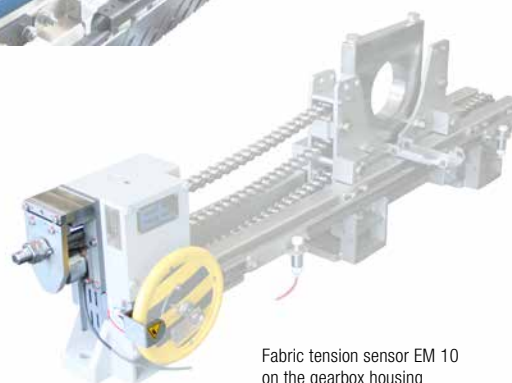

Fabric tension sensor EM 10 on the gearbox housing

#### Selection table

Type	Application	Dry	Wet	Nominal measuring force $F_N$ (kN)					
EM 10__T	SP 10	■		1	2	5	10	20	30
EM 10__N	SP 10		■	1	2	5	10	20	30

#### Technical data

##### Fabric tension sensor PD 80/90, EM 08 and EM 10

Accuracy class	1
Hysteresis	$\pm 0.15$ %
Non-linearity	$\pm 0.15$ %
Reproducibility	$\pm 0.1$ %
Temperature coefficient	$\pm 0.05$ %/10 K
Measuring principle	Full bridge strain gauge
Nom. resistance of strain gauge bridge	4 x 350 Ohm
Nominal characteristic value	2 mV/V
Output voltage	0 mV to 20 mV (at $F_N$ and $U_B$ 10 V)
Mechanical stop	$1.1 \times F_N$ (0 mV to 22 mV and $U_B$ 10 V)
Nominal measuring deflection	0.2 mm to 2 mm depending on type
Axial transverse force	Not permitted
Operating voltage Nominal value	10 V DC
Ambient temperature	+20 °C to +160 °C
Protection rating	IP 67

# Measuring amplifier CV 22

- Single-channel measuring amplifier for connecting max. two fabric tension sensors with strain gauge bridge
- Precision instrument amplifier with low temperature drift, high long-term stability and excellent linearity
- With potentiometer for zero point and tare adjustment as well as gain setting
- Internal reference voltage for measuring amplifier calibration without reference weights given exact knowledge of the wrapping angle and mounting position
- Optionally with housing and digital display PA
- Optionally with housing, digital display PA and command device NT



Measuring amplifier CV 22

## Control structure for measuring amplifier

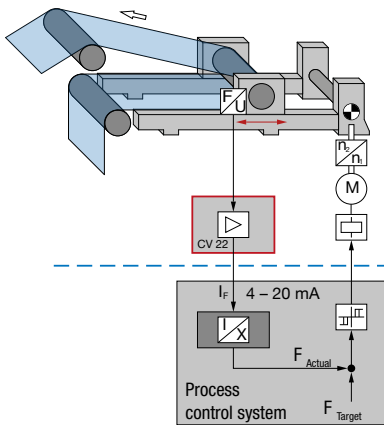

## Technical data

Accuracy class	0.1
Temperature coefficient of the nominal value of the zero signal of the bridge supply voltage	±0.3 %/10 K ±0.3 %/10 K ±0.04 %/10 K
Gain range	990 V/V to 3400 V/V 400 V/V to 1250 V/V 600 V/V to 2050 V/V 300 V/V to 1025 V/V
Strain gauge amplifier	1 x channel
Input voltage	0 mV to ±20 mV
Analog outputs	
Voltage	1 x 0 V to ±10 V (rise time 5 ms)
Voltage filtered	1 x 0 V to ±10 V (rise time 2 s)
Current	1 x 0/4 mA to 20 mA (rise time 5 ms)
Ambient temperature	0 °C to +60 °C
Operating voltage	
Nominal value	24 V DC
Nominal range	20 V to 30 V DC
Current consumption	0.2 A
Bridge supply voltage	
Nominal value	10 V DC
Nominal range	9 V to 13 V DC
Protection rating	
Top-hat rail mounting to DIN EN 50022	IP 00
With housing	IP 54
optional	IP 65
Dimensions (L x W x H)/weight	
Top-hat rail mounting to DIN EN 50022	121 x 22.5 x 110 mm / 0.14 kg
With housing	150 x 150 x 150 mm / 2.1 kg

## Digital measuring amplifier PA 62

- Digital two-channel measuring amplifier with display for connecting max. two fabric tension sensors with strain gauge bridge
- Menu-based, language-neutral commissioning wizard
- Online diagnostics for fabric tension sensors including wiring
- X-t plotter for long-term indication of the fabric tension
- Monitoring of the fabric tension for adjustable limits with digital alarm output
- Signal output analog or using Ethernet interface



Digital measuring amplifier with display PA 62

### Selection table

Type	Version
PA 62_0	As panel mounted kit with display
PA 62_1	In housing with display
PA 62_2	For top-hat rail without display
PA 620_	Without fieldbus
PA 621_	With fieldbus

### Technical data

Accuracy class	0.1
Measuring cycle time	1 ms
Strain gauge amplifier	2 x channels
Input voltage	±25 mV, 14 bits
Bridge supply voltage	10 V DC
Analog outputs	2 x 0 to 5/10 V 1 x 0/4 to 20 mA, $R_{max}$ 500 $\Omega$
Filter	$f_g = 0.2$ Hz to 20 Hz
Output signal (configurable)	Total signal / channel 1 / channel 2 / difference signal
Digital outputs	3 x floating, short-circuit proof
Output voltage	24 V DC, $I_{max}$ 0.5 A
Output signal (configurable)	Limit / Alarm / Status
Digital input	1 x floating
Input voltage	24 V DC
Input signal (configurable)	Tare / Recipe / Stop recording
Display and control unit	Color touch display (LCD) (not PA 62.2)
Interface	RJ45 Ethernet 100 Mbit (ODVA-compliant) Fieldbus EtherNet/IP, Profinet or UDP
Operating voltage	24 V DC
Nominal range	18 V to 30 V DC (incl. ripple)
Current consumption	0.2 A
Ambient temperature	+10 °C to +50 °C
Protection rating	IP 20 (top-hat rail mounting) IP 54 (panel mounted kit and housing)
Dimensions (L x W x H)/weight	
Panel mounted kit	100 x 100 x 50 mm / 0.44 kg
Housing	155 x 130 x 106 mm / 1.8 kg
Top-hat rail mounting	90 x 90 x 90 mm / 0.35 kg

# Fabric tension controller DC 04/24

- Extremely compact fabric tension controller with integrated digital inputs and outputs
- Three-point controller for actuation of a rotary current motor/solenoid valve
- CAN bus technology makes complex cabling unnecessary, instead replacing it with simple plug connections
- Software download via CAN bus
- Setup operation integrated on the control card
- Digital and analog input and output modules can be connected via SPI bus (Serial Peripheral Interface)

## Function modules

- Inputs for control device "Slacken" and "Tension" for clothing change, commissioning and service purposes
- Separate entry of 2 fabric tension target values for run-up time and production
- Digital inputs for monitoring system switches for tension carriage limit positions, motor protection and handwheel monitoring
- Monitoring of the supply voltage
- Digital alarm outputs for maximum control time, actual value exceeding threshold, hardware fault on the measuring amplifier, direction of rotation position sensor or felt cocking unit, position monitoring, manual mode, system switches and general alarm
- Additional error display via error codes on a 7-segment display on the control card and on the command station DO 20
- Correction of the actual fabric tension from changing wrapping on measuring roller
- Optionally with output of the actual target value and actual value for the fabric tension as well as the tension carriage position as analog signals from 0 to 10 V DC / 0 to 20 mA / 4 to 20 mA

## Control structure for fabric tension controller

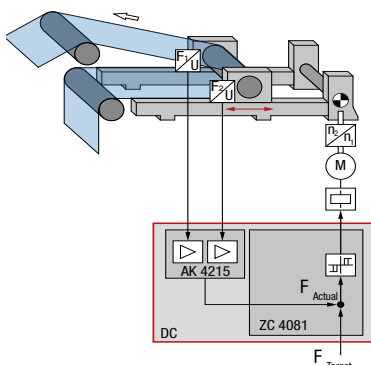

Fabric tension controller DC 04

## Selection table

Type	ZC 4081	AK 4215	AK 4022	DO 2000
DC 0420	■	■		
DC 0430	■	■	■	
DC 2420	■	■		■
DC 2430	■	■	■	■
ZC 4081	Control card			
AK 4215	Precision measuring amplifier for 2 fabric tension sensors from 0 to 20 mV (12 bits)			
AK 4022	Analog output module with 4 outputs from 0 - 10 V DC / 0 - 20 mA / 4 - 20 mA			
DO 2000	User interface with plain text display			

## Technical data

Cycle time	10 ms
Digital inputs	16 x floating
Input voltage for "0" signal	0 V to 3 V DC
Input voltage for "1" signal	10 V to 30 V DC max.
Input current	10 mA per input
Digital outputs	16 x floating and short-circuit proof
Output voltage for "1" signal	Supply voltage
Output current per output	1 A
Serial interface	
CAN bus level	+5 V DC (floating)
CAN baud rate	250 kBaud
Operating voltage	
Nominal value	24 V DC
Nominal range	20 V to 30 V DC
Current consumption	0.5 A
Ambient temperature	+10 °C to +50 °C
Protection rating/dimensions (L x W x H)/weight	
Top-hat rail mounting acc. to DIN EN 50022	IP 00 / 410 x 111 x 70 mm / 0.8 kg
with housing	IP 54 / 300 x 150 x 80 mm / 2.8 kg

# Command station DO 20

- User interface with user-friendly plain text display
- Structured depiction of the CAN network
- Simple "Setup Editor" for parameter setting during initial commissioning
- Display of target and actual fabric tension
- With fabric tension measurement on both sides, separate actual value display
- Display of error messages
- Multiple operation of up to eight control systems
- As an option, operation can be locked via a key switch
- Parameters for all network subscribers can be saved as a "backup" in the command station



Command station DO 20

Selection table		
Type	Panel mounted kit	With housing
DO 2000	■	
DO 2001		■

Technical data	
Operating voltage	
Nominal value	24 V DC
Nominal range	20 V to 30 V DC
Current consumption	200 mA DC
Ambient temperature	+10 °C to +50 °C
Serial interface	
CAN bus level	+5 V DC (floating)
CAN baud rate	250 kBaud
Dimensions	
Front frame panel mounting	152 x 138.4 mm
Cut-out for panel mounted kit	121 x 111.5 mm
With housing for field mounting	180 x 190 x 95 mm
Protection rating	
Panel mounted kit (when built-in)	IP 54
With housing for field mounting	IP 54
Weight DO 2000	0.55 kg
Weight DO 2001	1.3 kg
Language, operation	German, English, French, Italian, Spanish, Portuguese

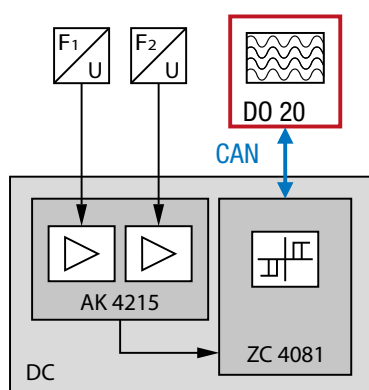

Block diagram DO 20

## Interfaces

Modern production facilities have a central control station or a control room. In this case the fabric tension measurement and control systems can be connected to different bus systems or to a PLC/IPC.

E+L offers a range of interfaces with standard protocols for this purpose. The interfaces contain a CAN connection with a corresponding bus driver module.

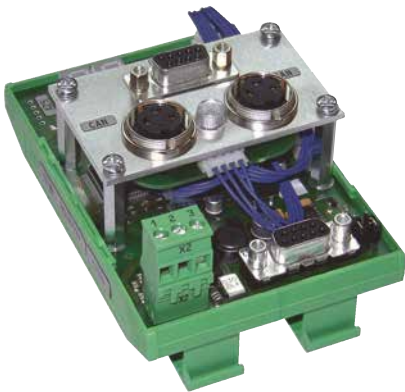

Interface DI B000

### Technical data DI B000

Interface	Profibus (DI B000) 2 x CAN at E+L system
Operating voltage Nominal value Nominal range	24 V DC 20 V to 30 V DC
Current consumption	0.2 A DC
Ambient temperature	+10 °C to +50 °C
Protection rating	IP 00
Dimensions (L x W x H) / weight Top-hat rail mounting in acc. with DIN EN50022	111 x 75 x 100 mm / 0.25 kg



Interface DG 0

### Technical data DG 0

Interface	Ethernet/IP (DG 0201) ControlNet (DG 040) PROFINET (DG 0701) 2 x CAN at E+L system
Operating voltage Nominal value Nominal range	24 V DC 20 V to 30 V DC (incl. ripple)
Current consumption	Max. 0.2 A DC
Ambient temperature	+10 °C to +60 °C
Storage temperature	-25 °C to +80 °C
Relative humidity	15 % to 95 % (non-condensing)
Protection rating	IP 20
Mounting	Top-hat rail mounting in acc. with EN 50022 (35 x 7.5 mm)
Dimensions (L x W x H)	125 x 76 x 133 mm
Weight	0.8 kg
Certification	CE conformity

# Networking

## CAN bus

All the functional modules of the digital control system (DCS) feature a CAN bus interface via which they are networked with each other. This feature ensures not only flexible adjustment of the E+L control system to new tasks but also guarantees maximum immunity to interference and minimum wiring effort.

A controller group can contain up to 16 participants, including e.g. sensors, controllers, interfaces, or command stations. Up to eight controller groups can be implemented together in a shared CAN network with a length of up to 160 m. A CAN extension DI 0010 is available for lengths of 160 m and upwards; this is simply plugged in between two CAN networks.

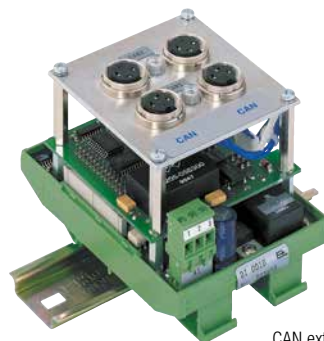

CAN extension DI 0010

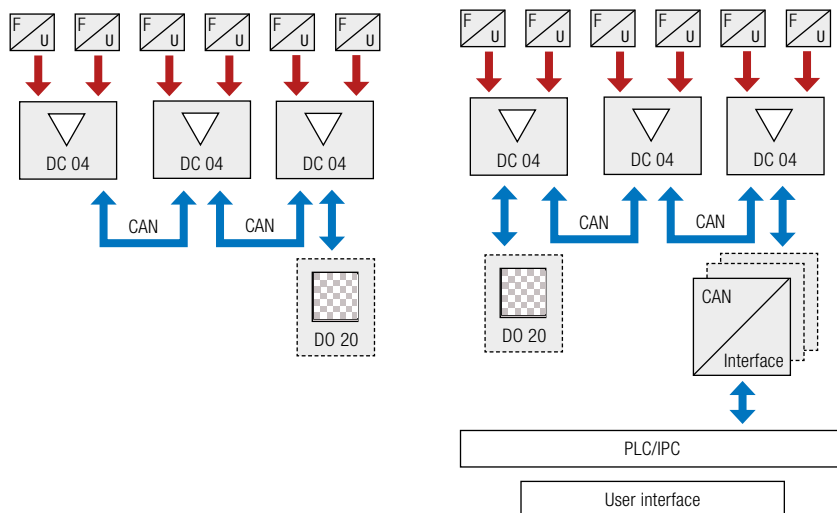

## User-friendly diagnostics with ELBUDDY diagnostic tool

Complex systems require a simple, clearly laid-out representation of the entire network. The ELBUDDY software tool for Windows computers depicts the CAN network in a structured form. At the same time, it also includes a convenient setup editor for adjusting all control parameters. In addition, ELBUDDY can also be used to both save and print out the entire CAN network.

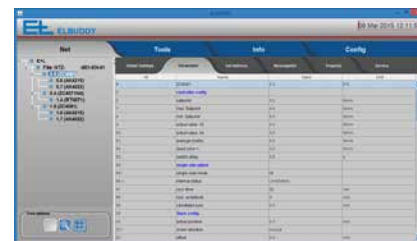
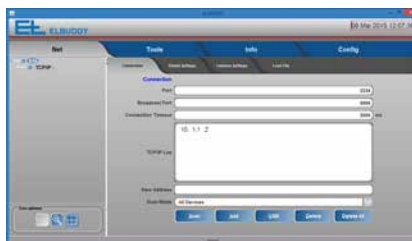

CAN-USB adapter ZC 40

# Networking with process control system

## System requirements

- Cycle times in the PLC of < 50 ms required
- Additional wiring effort for analog fabric tension sensors
- Additional analog inputs necessary for the fabric tension sensors and, if necessary, other sensors
- Additional space required in the program memory

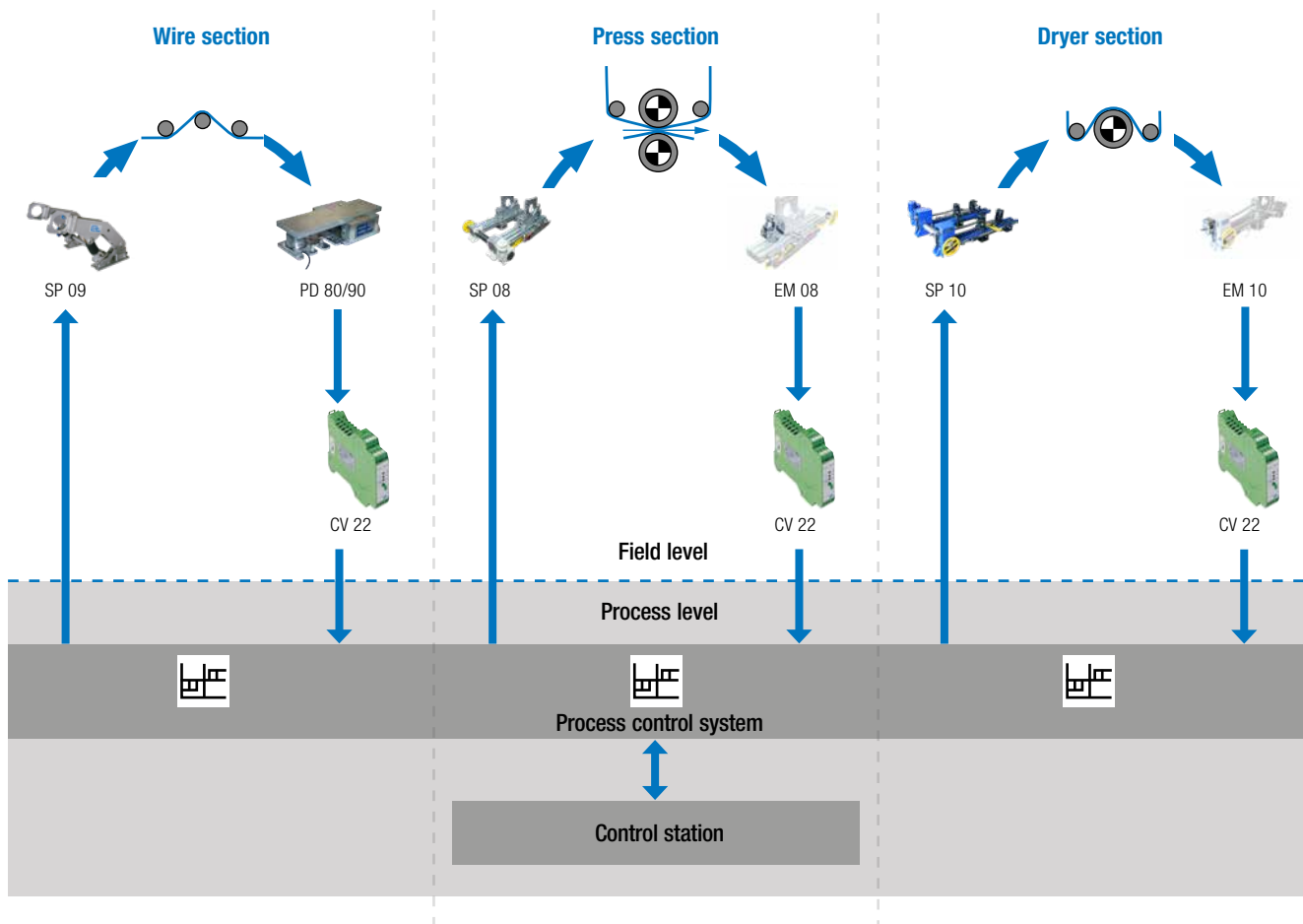

# Networking with E+L fabric tension control system

## Your benefits

- Stable fabric tension control due to independent, fast control loops
- No additional programming effort for fabric tension control necessary
- CAN bus technology ensures reliable data exchange and reduces the wiring effort
- Control loops closed by E+L components ensure high process stability

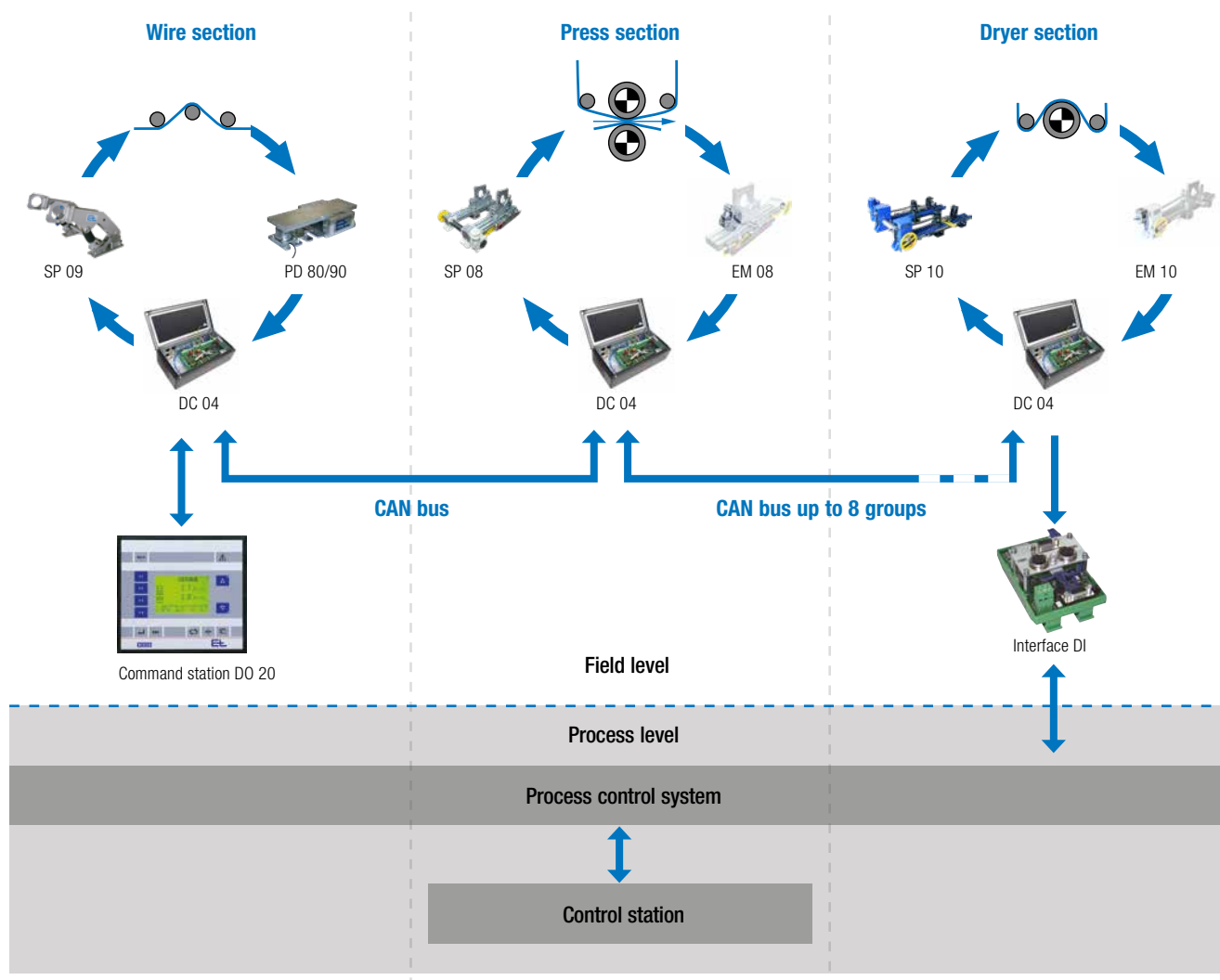

# Wrap angle compensation

Stretch roller is used as the measuring roller for the fabric tension measurement with changing wrapping.

## Your benefits

- Optimal control concept for dryer groups without external rollers
- Due to high wrapping on the stretch roller, optimal measuring signal for fabric tension acquisition
- No dead time between measuring roller and stretcher roller
- Reduced installation costs
- No fabric tension measurement on the roller for the wire/felt guider

## Electronic compensation

- Acquisition of the stretch roller position using a position sensor FE 07
- The actual fabric tension is adjusted to suit the position of the stretch roller
- The calculation is already included in the fabric tension controller DC 04/24
- Can be used in spindle and chain-type stretcher

## Mechanical compensation

- No additional electronics required
- Due to clever positioning of the pivot point and measuring unit, the measuring signal remains constant over a defined stretcher stroke
- Can be used with asymmetrical roller arrangement
- Can be used on lever-arm, spindle and chain-type stretcher

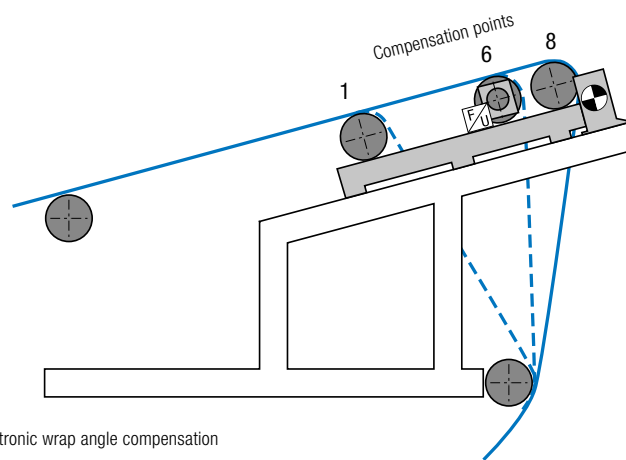
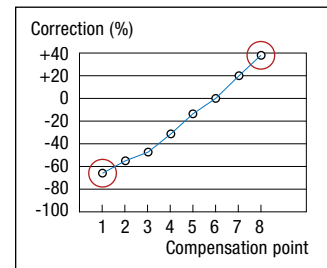
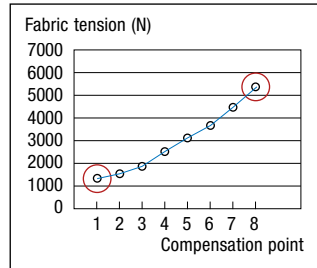

Function – electronic wrap angle compensation

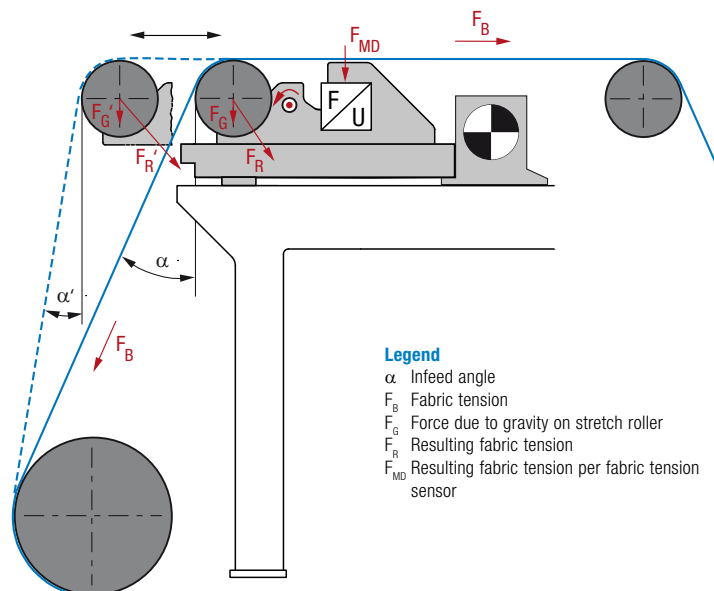

### Legend

- $\alpha$  Infeed angle
- $F_B$  Fabric tension
- $F_G$  Force due to gravity on stretch roller
- $F_R$  Resulting fabric tension
- $F_{MD}$  Resulting fabric tension per fabric tension sensor

Function – mechanical wrap angle compensation

### Control structure for electronic wrap angle compensation

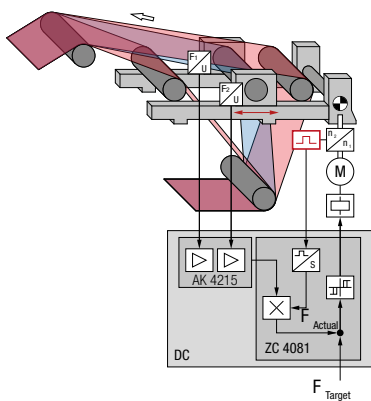

Electronic wrap angle compensation

Fabric tension sensor EM 10

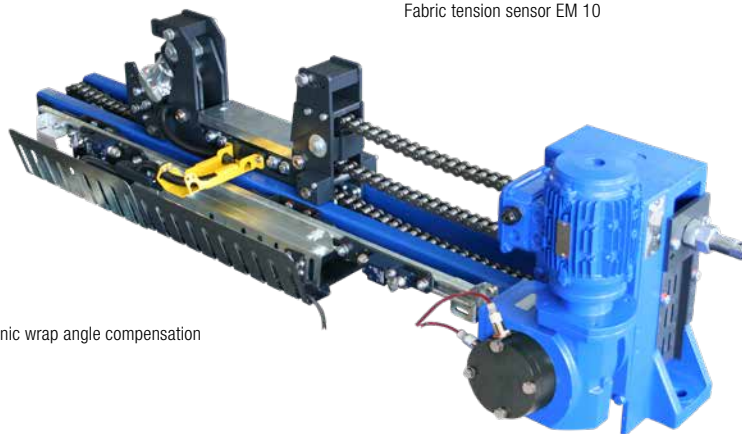

Position sensor FE 07

#### Position sensor FE 07

Operating voltage	24 V DC
Nominal value	10 V to 33 V DC
Nominal range	+10 °C to +130 °C
Ambient temperature	IP 68
Protection rating	

### Control structure for mechanical wrap angle compensation

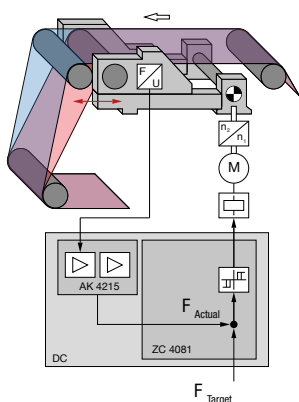

Mechanical wrap angle compensation

Fabric tension sensor EM 08

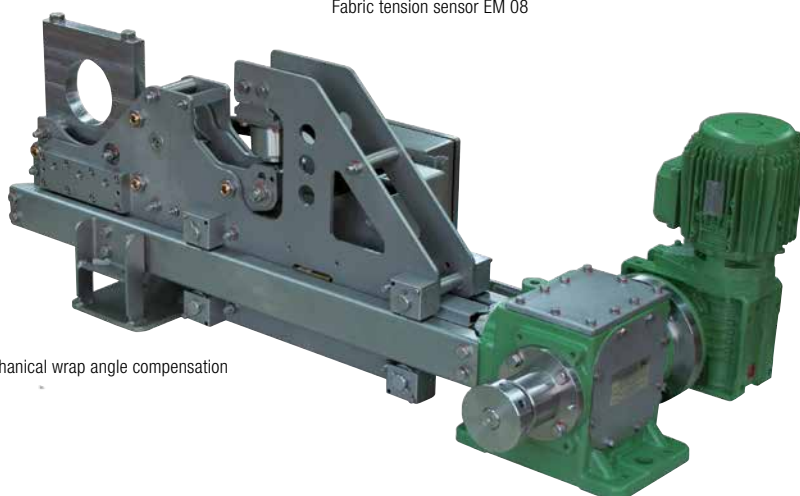

# Felt cocking unit VM 08/10

- Automatic felt cocking of press felts
- Continuously adjustable for stroke and time
- One-sided adjustment of the stretch roller
- Replaces classic handwheel
- System enhancement with all necessary components
- Optionally for spindle and chain-type stretcher

## Your benefits

- Reduced vibration with increasing production speed
- Increased service life of the press felt and roller bearings
- Improved paper quality
- Increase in the machine productivity

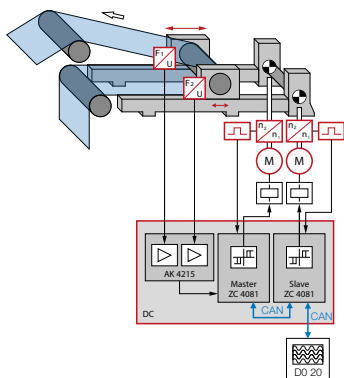

Block diagram for felt cocking unit VM 08/10

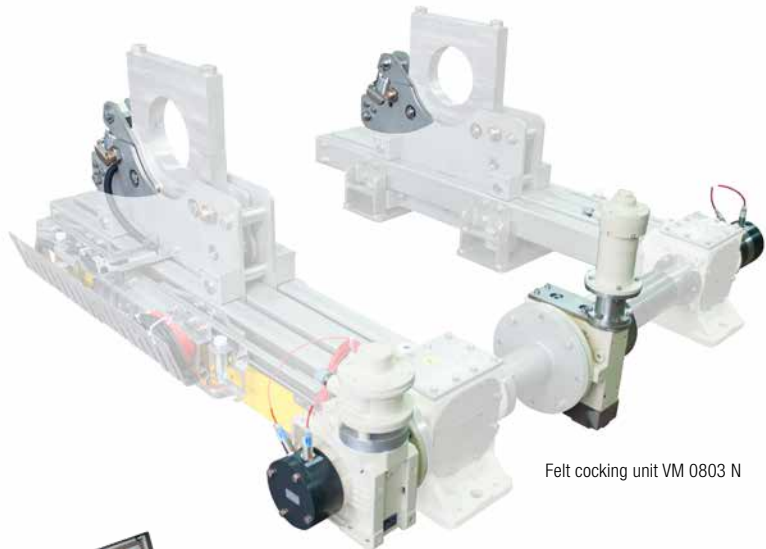

Felt cocking unit VM 0803 N



Fabric tension controller DC 04\_8

## Technical data

Type	VM 10__T*	VM 08__N*
Actuating accuracy	1 mm	1 mm
Actuating travel max.	70 mm	70 mm
Actuating speed max.	22.8 mm/min	22.8 mm/min
Material	Steel/cast iron, painted	Stainless steel/cast iron, painted
Area of use	Dry	Wet
Power	0.12 kW	0.25 kW
Operating voltage		
Range 1	200 V - 240 V / 346 V - 420 V 50/60 Hz	200 V - 240 V / 346 V - 420 V 50/60 Hz
Range 2	230 V - 290 V / 400 V - 500 V 50/60 Hz	230 V - 290 V / 400 V - 500 V 50/60 Hz
Range 3	290 V - 330 V / 500 V - 575 V 50/60 Hz	290 V - 330 V / 500 V - 575 V 50/60 Hz
Current consumption		
Range 1	1.3 A / 0.7 A 50 Hz    1.1 A / 0.6 A 60 Hz	2.5 A / 1.4 A 50 Hz    2.1 A / 1.2 A 60 Hz
Range 2	On request	On request
Range 3	On request	On request
Ambient temperature	+10 °C to +130 °C	+10 °C to +60 °C
Protection rating	IP 66	IP 66
Weight	Approx. 32 kg	Approx. 90 kg

\* N = Wet, T = Dry

# Accessories

## Command device NT 52/53

- Simple local operation
- For fixed installation or portable usage

### Your benefits

- Optimal for clothing change, commissioning and service purposes



Command device  
NT 5385



Command device  
NT 5226

Technical data		
Type	NT 5385	NT 5226
Material	Plastic	Stainless steel
Operating voltage Nominal value	24 V DC	24 V DC
Ambient temperature	+10 °C to +60 °C (housing) +10 °C to +120 °C (base)	+10 °C to +60 °C
Protection rating	IP 65	IP 67
Dimensions (L x W x H)	314 x 80 x 90 mm	150 x 150 x 80 mm
Weight	0.8 kg	1.5 kg

## Digital display PA 1401

Digital display for indicating the current fabric tension on a bright, 3 1/2-digit LED display. The compact, space-saving panel mounted kit is available with 24 V DC connection voltage.

- Optionally with housing and command device NT
- Optionally with housing and measuring amplifier CV
- Optionally with housing, measuring amplifier CV and command device NT



Technical data	
Display	3 1/2 digits, 7 segments
Digit height	14 mm
Resolution	±1999
Overflow indication	only the "1" in the first digit illuminates
Accuracy	0.2 %
Measuring rate	Approx. 3 s
Measuring inputs	0 V to 10 V 0 mA to 20 mA 4 mA to 20 mA
Operating voltage Nominal value	24 V DC
Current consumption	150 mA
Ambient temperature	0 °C to +50 °C
Protection rating Panel mounted kit (when built-in) Optional	IP 54 IP 65
Dimensions (L x W x H) Panel mounted kit Cut-out for panel mounted kit	96 x 85 x 24 mm 92 x 22.2 mm (mounting depth 75 mm)
Weight	110 g

# Questionnaire 1/2

## General data

Customer			
Street			
Zip code		City/town	
Country		Internet	
Contact person			
Phone		E-mail	
Paper machine no.	Project	Paper machine manufacturer	

## Technical data

Installation point	<input type="checkbox"/> Wire section	<input type="checkbox"/> Press section	<input type="checkbox"/> Dryer section
Ambient temperature	°C	Machine speed	m/min
Max. felt/wire tension	N/mm	Felt/wire width	mm

## Specification sensor

Type	<input type="checkbox"/>  Fabric tension sensor PD 80	<input type="checkbox"/>  Fabric tension sensor PD 90
------	--	--

### Mounting position for the measurement

Machine drawing or sketch (as seen from operator's side) with:

- Installation angle
- Direction of felt/wire travel
- Infeed and outfeed angle

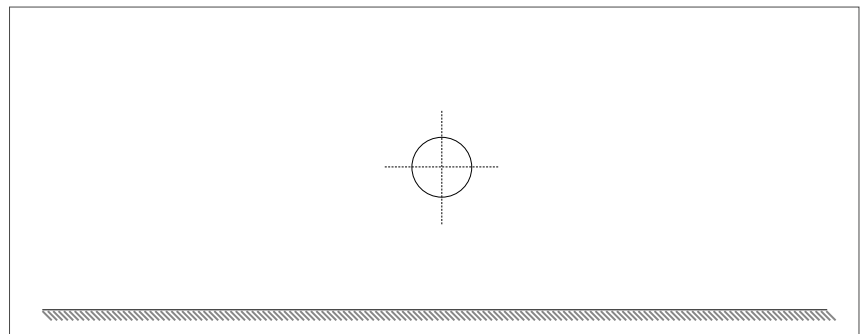

Fabric tension measurement	<input type="checkbox"/> On one side	<input type="checkbox"/> On both sides	
External components (mounted separately)	<input type="checkbox"/> Stationary doctor _____ kg <input type="checkbox"/> Oscillating doctor _____ kg	<input type="checkbox"/> Other (description and weight) _____ kg	
Weight	Measuring roller _____ kg	Roller bearing _____ kg	
Roller bearing (for PD 90)	<input type="checkbox"/> Cylindrical Ø _____ mm	<input type="checkbox"/> Spherical Ø _____ mm	
Pedestal bearing (for PD 80)	Weight _____ kg	Foot plate ___ x ___ x ___ mm	Center height _____ mm



# Questionnaire 2/2

## Specification actuator

<b>Type</b>	 <input type="checkbox"/> Lever-arm type stretcher SP 09	 <input type="checkbox"/> Spindle-type stretcher SP 08	 <input type="checkbox"/> Chain-type stretcher SP 10
-------------	--	---	--

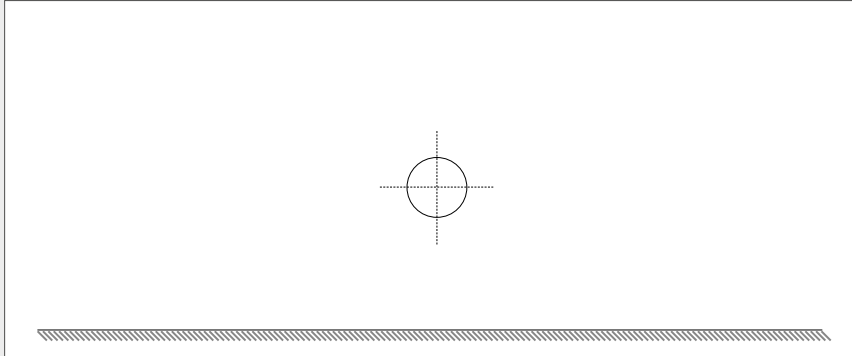
<b>Stretcher stroke/actuating travel</b>	<input type="checkbox"/> SP 09 _____ mm	<input type="checkbox"/> SP 08 _____ mm	<input type="checkbox"/> SP 10 _____ mm
--	---	---	---

<b>Mounting position for the measurement</b> Machine drawing or sketch (as seen from operator's side) with: <ul style="list-style-type: none"> <li>▪ Installation angle</li> <li>▪ Direction of felt/wire travel</li> <li>▪ Infeed and outfeed angle</li> </ul>	
	<input type="checkbox"/> Constant roller wrapping <span style="margin-left: 200px;"><input type="checkbox"/> Adjustable roller wrapping</span>

<b>Fabric tension measurement</b>			<input type="checkbox"/> On one side	<input type="checkbox"/> On both sides
 EM 08/10	 EM 10	 PD 80/90		

<b>External components</b>	<input type="checkbox"/> Doctor _____ kg	<input type="checkbox"/> Cleaner _____ kg	<input type="checkbox"/> Spray tube _____ kg
<b>Weight</b>	Stretch roller _____ kg	Roller bearing _____ kg	
<b>Roller bearing</b>	<input type="checkbox"/> Cylindrical Ø _____ mm	<input type="checkbox"/> Spherical Ø _____ mm	
<b>Pedestal bearing</b>	Weight _____ kg	Foot plate ___ x ___ x ___ mm	Center height _____ mm
<b>Painting</b>	Brilliant blue RAL 5007	Silver gray RAL 7001	Special color RAL
<b>Type of actuating drive</b>	<input type="checkbox"/> Three-phase motor 3 x _____V _____Hz	<input type="checkbox"/> Pneumatic motor (max. 90 °C)	
<b>Felt cocking unit VM</b>	<input type="checkbox"/> Optionally for spindle-type stretcher SP 08	<input type="checkbox"/> Optionally for chain-type stretcher SP 10	

## Specification fabric tension control / fabric tension measurement

<b>With E+L fabric tension controller</b>	<input type="checkbox"/> Fabric tension controller DC 04/24	<input type="checkbox"/> Profibus DI <input type="checkbox"/> EtherNet/IP <input type="checkbox"/> UDP <input type="checkbox"/> Analog output module AK 40
<b>With analog measuring amplifier</b>	<input type="checkbox"/> Measuring amplifier CV 22	<input type="checkbox"/> With digital display PA 14
<b>With digital measuring amplifier</b>	<input type="checkbox"/> Measuring amplifier PA 62	<input type="checkbox"/> For top-hat rail without digital display
<b>Optional command device</b>	<input type="checkbox"/> Command device NT 52	<input type="checkbox"/> Command device NT 53
<b>Operating voltage</b>	<input type="checkbox"/> 24 V DC	<input type="checkbox"/> With power supply unit _____ V _____ Hz

Date	Issuer	
------	--------	--

## Services from A – Z

---

### We help from the very beginning

At the start with your new fabric tension measuring and control system, a thorough analysis is undertaken by your personal E+L advisor. As a specialist for the complete product range from Erhardt+Leimer, your advisor will be pleased to advise you also about other topics related to your production.

### Project planning with experience

The project planning team in our headquarters in Augsburg will prepare a bespoke solution for you, even for difficult applications. With the experience of numerous installations all over the world, our specialists do not view problems in the field of fabric tension measuring and control in isolation, but always in the overall process-related context.

### Complete solutions

Erhardt+Leimer will provide you with a complete solution from a single source. On request, we can also supply the system complete with a controller installed inside the control cabinet. Our experts will be glad to help you make the necessary adjustments after installation to ensure that your new system is perfectly set up for the specific conditions on site.

### Worldwide service

After installation in your premises, our work is not yet complete, because for E+L, intensive customer service is a matter of course. Our close-knit, worldwide service network makes use of the latest diagnostic technology, such as teleservice or modem-controlled remote diagnostics. Whether complete installation and commissioning, repair or maintenance – just give us a call and we will address your requirements.

### Training for every application area

For the full utilization of the high performance of your new systems from E+L, even in complex applications, we offer machine manufacturers and users of our products "help for self-help". We offer one-day or multi-day training courses for installation and service technicians in our Augsburg training center or on your premises.





S

ERVICE

is our  
top priority

#### Head office

Erhardt+Leimer GmbH  
Albert-Leimer-Platz 1 · 86391 Stadtbergen, Germany  
Phone: +49 (0)821 2435-0  
info@erhardt-leimer.com · www.erhardt-leimer.com

#### Subsidiaries

E+L Elektroanlagen Augsburg, Germany · E+L Steuerungstechnik St. Egidien, Germany  
E+L Bradford, England · E+L Mulhouse, France · E+L Stezzano, Italy · E+L Bucharest, Romania  
E+L Barcelona, Spain · E+L Burlington, Canada · E+L Duncan, S.C., USA · E+L Guarulhos-São Paulo, Brazil  
E+L Ahmedabad, India · E+L Hangzhou, China · E+L Tao Yuan, Taiwan Province · E+L Yokohama, Japan  
E+L Seoul, Republic of Korea · E+L Bangkok, Thailand

Subject to technical changes without notice · GRU-250785-EN-05 · 05/2025 · 363850

